

TITLE

INSPECTION AND REPLACEMENT OF NOSE GEAR DRAG LINKS

EFFECTIVITY**MODEL**

Lancair IV, IV-P, IV-PT, and Legacy

SERIAL NUMBERS

ALL

REVISION AND ISSUE DATE

REV #	DATE	DESCRIPTION	APPROVED BY
IR	07/21/2022	Initial Revision	DIEGO LOPEZ
A	08/24/2022	Notes provided by LOBO	DIEGO LOPEZ

1. SUBJECT

1.1 Investigation into abnormal wear in the scissor link over-center pivot joints and associated bronze bushings. The subject parts are referred to as the Over center Link Assy. (one part) and lower drag links (two parts) in the Lancair build manuals. Some aircraft incorporated the Lancair improved drag link parts with bronze bushings; however this wear and deformation caused the bushings to bind to the over-center links limiting the function of the pivot, and potentially causing retraction of the nose gear upon touchdown.

1.2 This Service Bulletin (SB) describes action required by operators of aircraft in the field.

2. COMPLIANCE

2.1 Inspection: At the earliest convenience, before any further flights, perform inspection described in Section 6. If any evidence of wear or malfunction is detected, replace two lower drag links and attachment hardware with superseded components.

3. COST

3.1 Estimated labor associated with inspection is one (1) man-hour. Estimated labor associated with lower drag link replacement is three (3) hours.

4. LOCATION

- 4.1 Replacement of the drag links and hardware can be accomplished at any appropriately certificated agency, certificated person or Repairman.

5. CONTACT

- 5.1 For additional information regarding the inspection or to make arrangements to purchase a drag link upgrade kit, please contact:

Lancair International, LLC
122 Howard Langford Drive
Uvalde, TX 78801
Phone: (830) 423-3005, Ext. 703
E-mail: sales@lancair.com

6. INSPECTION

- 6.1 Determine if the aircraft is equipped with the original or improved design lower drag links. The original upper and lower drag links were joined by two AN4 pivot bolts with cotter-pinned castle nuts that allow them to pivot on the bolts during gear retraction (Figure 1). The improved lower drag links added a bronze bushing to each of the lower drag links at the center pivot point (Figure 2). Both styles of Lower Drag Links are **superseded** by the new components detailed in this Service Bulletin (PN 433-1001, Lower Drag Link LH and PN 433-1002, Lower Drag Link RH).

- 6.2 Visually inspect the lower drag link installation as follows:



Figure 1
Original Design Lower Drag Links



Figure 2
Improved Design Lower Drag Links

WARNING: When performing this inspection and drag link replacement, ensure that the nose of the aircraft is properly lifted, secured and shored to prevent the nose of the aircraft from collapsing to the ground which can cause damage, injury or even death. An engine hoist secured to the lifting ring on the engine is best for lifting the nose wheel off the ground.

- 6.2.1** Aircraft equipped with the original steel-on-steel pivots (without the bronze bushings) will have a bolt with a castle nut secured with a cotter pin. Aircraft equipped with the improved pivots will have a tension bolts and locking nut.
- 6.2.1.1** Using a straightedge, check that the drag links are over-center shown in Figure 3. There is no “over-center distance” specified, but a range from $\frac{1}{4}$ ” to $\frac{1}{2}$ ” as measured from the centerline of the pivot bolt joining the upper and lower links is ideal.



Figure 3

- 6.2.1.2** With the hydraulic pressure zeroed, remove the emergency extension gas spring. It is easier if you first remove the long bolt connecting the nose strut to the lower drag links per the Lancair assembly manual instructions. With gas spring disconnected reinsert the long bolt joining the lower drag links to the strut.
- 6.2.1.3** With the gas spring disconnected and the nose wheel off the ground, apply fore/aft force to the nose wheel, and observe any movement of the pivot point between the upper and lower drag links. Any amount of wear in the pivot joints between the drag links will cause the joint to move when fore/aft pressure is applied to the nose wheel because the steel-on-steel contact point between the ears of the lower drag links

and the upper link acts as the initial pivot point for the assembly. If wear in the joint is sufficient to allow it to move over-center as measured in step 6.2.1.1 above, the nose gear is restrained from retracting at touchdown only by the combined hydraulic and gas spring pressure. If either fails, the nose gear could retract upon a normal touchdown.

6.2.1.4 If the above test indicates the drag link pivot point moves past, or close, to the over-center position, replacement of the drag link assembly is dictated. Once this joint develops free play, the wear rate will increase exponentially until it fails.

6.2.1.5 In most cases, replacement of the two lower drag links with the superseded design lower drag links and the correct installation of the new hardware between the upper and lower links will correct this problem. If the holes in the upper over center link have been worn excessively, replacement of this part is also indicated.

6.2.2 If your aircraft is equipped with the improved design lower drag links and bronze bushings, inspect to ensure that the bushings are not deformed or obstructing the motion of the Over Center Link. Perform the procedure shown in Step 6.2.1.1 thru 6.2.1.5. The hardware should consist of the proper tension bolts and self-locking steel nuts torqued to 90-100 in/lbs. It is not acceptable for these bolts to turn with less than the specified torque applied.

Lancair recommends replacement of lower drag links having bronze bushings installed with the new style lower links. If lower links with bronze bushings are retained, they should be inspected IAW steps 6.2.1.1 through 6.2.1.5 at least annually.

6.2.3 Other recommended checks that can be performed at this time:

6.2.3.1 With the gas spring and hydraulic actuator disconnected, check for free swing, without binding, of the upper strut pivot points from full extension to full retraction. Any binding is cause for further investigation.

6.2.3.2 With the gas spring and hydraulic actuator disconnected, check the side-to-side movement of the upper strut in the motor mount pivots. Any movement greater than 0.01" should be corrected by shimming the bearing mounting blocks per the Lancair assembly manual. Side to side play at this pivot contributes to nose wheel shimmy.

- 6.2.3.3** Remove and test the gas spring for a minimum of 100 lbs. compression force. Replace if less than 90 lbs. force measured. This test is recommended along with an in-flight emergency extension test, at least annually.

7. SERVICE / ACTION

- 7.1** The original upper and lower nose gear drag links were joined with a drilled bolt and castellated nut that permitted the links to pivot on the bolt. The improved lower drag links were joined with tension bolts and locking nut, pivoting on the bronze bushings. The new design of Lower Drag Links REQUIRE the original drilled bolts/castellated nuts or the tension bolts/locking nuts, be replaced with Self-Locking Bolt provided with the new lower drag link kit of parts. Use of standard AN hardware for these pivot points between the upper and lower drag links is UNACCEPTABLE. We strongly recommend do NOT re-use the original bolts, please discard such hardware.
- 7.2** Procedure (See Figure 2 and 4):
- 7.2.1** Lubricate lightly and install the new 433-1001 Lower Drag Link LH and 433-1002 Lower Drag Link RH.
- 7.2.2** Install the new lower links to the over center link using NEW NAS6204-9H Self Locking Bolts (head on inside of the assembly, threads going outboard) and AN960-416 Washers.
- 7.2.3** Before attaching the 433-1001 & 433-1002 Lower Drag Links to the nose strut, torque the above bolts to 90-100 in./lb. and ensure each of the two lower links will pivot on the upper link through the full range of movement required during gear retraction.

Do not continue re-assembly until this condition is satisfied for both lower links. This may require removal of paint from the mating surfaces.

If the full range of motion is achieved, safety wire both NAS6201-9H Self Locking Bolts to the corresponding Lower Drag Link. A small hole for safety wire can be found on the curvature of the stop.

- 7.2.3** Make an appropriate entry to the aircraft logbook.

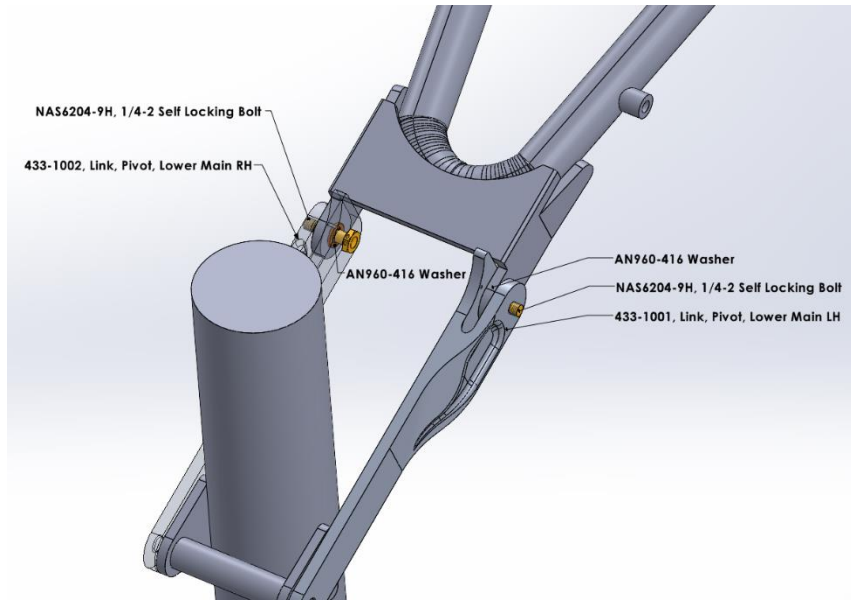

Figure 4

NOTE: The Upper Over center Link Assembly has been upgraded to a stronger part by SB074-0111. If you have not complied with this service bulletin, it is recommended that SB074-0111 be incorporated at this time.

SB074-0111 applies to both over center link tab configurations shown in Fig. 4, SB074-0111 also addresses the installation of a Hydraulic actuator end with a spherical bearing. For further details on the inspection please refer to SB074-0111.

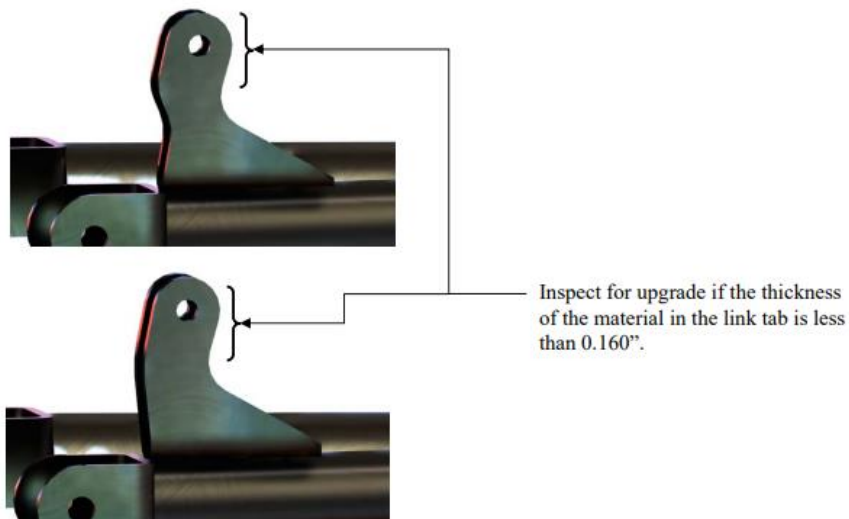

Figure 5

7.3 The following kit is necessary for all airplanes when incorporating SB078-0722.

MATERIAL - Cost and Availability

PART NUMBER		AVAILABILITY			COST
SB078-01		*			*
NEW P/N	QTY.	NOMENCLATURE	OLD P/N	INSTRUCTIONS/ DISPOSITION	
SB078-01	1	Kit , consisting of the following parts:			
433-1001	1	Lower Drag Link LH	GM027-4 / 433-0001	Discard	
433-1002	1	Lower Drag Link RH	GM027-4 / 433-0001	Discard	
NA	2	Bronze Bushings	4722	Discard	
NAS6204-9H	2	Bolt, ¼-28 Self Locking	AN4-7 / AN4-11A	Discard	
AN960-416	2	Washer	AN960-416	Discard	
NA	2	Nut	AN310-4 / AN363-428A	Discard	

* Please contact Lancair Parts for current cost and availability of parts listed in this service bulletin. Phone toll free 1-866-LANCAIR or 1-830-423-3005. Send Email to: sales@lancair.com.

Based on availability and lead times, parts may require advanced scheduling.



SB078-0722

Record of Compliance

Please record findings associated with this SB, including zero defects to:

Lancair International. LLC
122 Howard Langford Drive
Uvalde, TX 78801
Phone: (830) 423-3005, Ext. 710
E-mail: chip@lancair.com

Aircraft Owner: _____

Aircraft Registration Number: _____

Aircraft Total Time: _____ Notes

and Findings:

Report Submitted By: _____ Date: _____