

Revision List: Supplement – Legacy Fixed Gear

The following list of revisions provides the updates to the Legacy Fixed Gear (FG) construction supplement. Under the “Action” column, “R&R” directs you to remove and replace the pages affected by the revision. “Add” directs you to insert the pages shows and “R” to remove the pages.

Pages Affected	Revision # and Date	Action	Description
S.1	1/08-10-2007	R & R	Updated table of contents for new page S.23B.
S.2 - S.4	1/08-10-2007	R & R	Updated part number lists for changes made in supplement’s instructions and graphics.
S.8, S.13, S.21, S.23, S.32, S. 33	1/08-10-2007	R & R	Updated part numbers in graphics and in instructions.
S.23B	1/08-10-2007	Add	New page describing the assembly of the nose wheel and tire.

Supplement–Legacy Fixed Gear

S.1 Introduction	S.1
S.2 Parts Used in this Supplement	S.2
S.3 Preparing for the Main Gear Installation	S.5
S.3.A Leveling the Fuselage	S.5
S.4 Installing the Gear Legs	S.6
S.4.A Positioning the Gear Leg	S.6
S.4.B Installing the Gear Leg	S.6
S.4.C Setting the Toe-in	S.11
S.4.D Installing the Axle and the Wheel	S.14
S.5 Installing the Main Gear Fairings	S.17
S.5.A Main Gear Fairings	S.17
S.5.B Fuselage Gear Fairings	S.22
S.6 Installing the Nose Gear	S.23
S.6.A Installing the Nose Gear Strut	S.23
S.6.B Connections Between the Nose Gear Fork and Wheel Bracket	S.23
S.6.C Assembling the Nose Wheel and Tire	S.23B
S.6.D Installing the Nose Gear Fork	S.24
S.6.E Installing the Nose Gear Mounting Plate	S.25
S.6.F Nose Gear Leg Fairing	S.27
S.7 Installing the Idler Assembly	S.29
S.7.A Aligning the Idler’s Base Bracket	S.29
S.7.B Installing the Idler’s Base Bracket	S.30
S.8 Modifications to the Fuel System	S.31
S.9 Appendix A	S.32
S.9.A Alternate Air Assembly for the TNIO 360/390	S.32

S.1 Introduction

The Legacy Fixed Gear Kit is shipped with the standard *Legacy Assembly Manual*. You will need to use that manual for the majority of the building of your Legacy Fixed Gear. But there are some sections that are different. This Legacy FG Supplement provides the instructions for, and replaces the following sections of the *Legacy Assembly Manual*:

Supplement Section	Replaces Chapter in Legacy Assembly Manual	Replaces these Sections of the Chapter
Main Gear Installation	Ch. 3 - Wing Systems	E. Main Gear Doors F. Main Gear Installation H. Center Wing Section Hydraulics
	Ch. 16 - Hydraulic Systems Completion	Entire chapter 16 is not installed.
Nose Gear Installation	Ch. 13 - Firewall Forward	D. Nose Gear Installation F. Nose Gear Doors G. Nose Gear Micro Switch
Wheel Pants and Fairings	All New Material (Not in standard assembly manual)	
Aileron Idler Modifications	Ch. 6 - Aileron Controls	B.3 on page 6-6
Fuel System Modifications	Ch. 4 - Fuel Systems	C. Fuel Supply Lines on page 4-5 E. Fuel Return Lines on page 4-9
Appendix – Alternate Air Assembly for the IO 360	New Information	New Information

S.2 Parts Used in this Supplement

Aileron Idler

Item	Part Number	QTY	Description
1)	209-0001	1	Bracket for aileron idler
2)	4581	1	Bellcrank assembly with bearing
3)	AN3-11A	2	Bolt
4)	AN365-1032A	2	Nylock nut
5)	AN365-428A	5	Nylock nut
6)	AN4-11	1	Bolt
7)	AN4-11A	2	Bolts
8)	AN960-416	7	Washers
9)	CD315-12	4	Washers, special/tapered
10)	F35-14	2	Rod-end bearing
11)	MS24694-S104	4	Bolts (bracket to spar)

Composite parts for Wheel Pants and Fairings

Item	Part Number	QTY	Description
1)	2044A	1	Nose gear leg fairing
2)	2044F	1	Nose gear fuselage fairing
3)	7043	2	Gear leg fairings
4)	7045	1	Nose gear pant
5)	7045L	1	Main gear pant, left
6)	7045R	1	Main gear pant, right
7)	7045LA	1	Main gear pant brake cover, left
8)	7045RA	1	Main gear pant brake cover, right
9)	7048L	1	Fuselage gear fairing, left
10)	7048R	1	Fuselage gear fairing, right

Nose Gear

Item	Part Number	QTY	Description
1)	212-0041	1	Nut plate, nose fork
2)	212-0073	2	Plate, Keeper, Nose Gear
3)	229-0005	1	Link, Nose Gear
4)	432-0002	1	Nose Gear Cylinder
5)	433-0000	1	Nose Fork
6)	3455	1	Nose gear fearing mounting plate
7)	4717-01	1	Pivot Bearing Block, Left
8)	4717-02	1	Pivot Bearing Block, Right
9)	4717-03	2	Bearing
10)	4798	1	Spacer, Axle, Nose Wheel
11)	3326381K103	2	Nose Gear Bushings
12)	6381K103	2	Bushing, Nose Gear
13)	AN3-3A	4	Bolt
14)	AN363-428	3	Lock Nut 1/4"
15)	AN365-428	1	Nylock nut
16)	AN365-528A	3	Nut, Nylock
17)	AN4-23A	3	Bolt
18)	AN426AD-4-4	8	Solid rivets
19)	AN4-47A AN4-51	1	Bolt
20)	AN5-17A	3	Bolts
21)	AN960-10L	4	Washer, Lite
22)	AN960-416L	8	Washer Thin
23)	AN960-516	3	Washer, 5/16"
24)	GM035-2	1	Nose gear wheel with bearings
25)	GM035-2	1	Nose gear wheel with bearings
26)	GM038	2	Bushing, Axle, for nose wheel
27)	K1000-5	4	Nut plates
28)	AN960-516 MS20002C5	4	Washers
29)	AN5-11A MS21250-05013	2	Bolt

Nose Gear (Continued)

Item	Part Number	QTY	Description
30)	AN5-12A MS21250-05015	2	Bolt
31)	RR-01	2	Circlip
32)	TB-1-05	1	Tow Bar Adapter
33)	TR-5 x 8ply	1	Tire Nose Gear
34)	Z02E276	1	Axle, Nose Gear
35)	AN365-524A	4	Nuts

Main Gear

Item	Part Number	QTY	Description
1)	075-00800	2	Torque Plate
2)	117-0005	4	Main axle spacer
3)	121-0000	2	Axle, FG
4)	209-0029	1	Bracket, Left Wheel Pant
5)	209-0030	1	Bracket, Right Wheel Pant
6)	7702	2	Main Landing Gear Legs
7)	7703-01	1	Upper Leg Attach, left
8)	7703-02	1	Upper Leg Attach, right
9)	7705-01	1	Axle Mount, Left
10)	7705-02	1	Axle Mount, Right
11)	7707	2	Link, Upper Leg Attach Assembly
12)	AN365-428A	9	Nut, Nylock
13)	AN365-528A	10	Nut, Nylock
14)	AN4-12A	8	Bolt
15)	AN4-16A	4	Bolt
16)	AN4-20A	4	Bolt
17)	AN4-22A	2	Bolt
18)	AN5-6A	12	Bolt
19)	AN960-416	12	Washer
20)	AN960-416L	4	Washer, Thin

Main Gear (Continued)

Item	Part Number	QTY	Description
21)	AN960-516	18	Washer
22)	AN970-4	4	Large Area Washer
23)	MS24694-S154	8	Screw countersunk

Fuel System

Item	Part Number	QTY	Description
1)	4805	2	Fuel hose #8, straight-to-straight.
2)	2240-6-8S	1	Bulkhead fitting (3/8" NPT to #8 flare)
3)	C5205x8x4	1	Pipe connector fitting (1/2" tube, 1/4" male pipe)
4)	C5365x8	1	45 deg. elbow fitting with O-ring (1/2" tube, 1/2" pipe)
5)	C5405x6x8	2	Male elbow fitting (3/8" tube, 1/2" male)

Alternate Air Assembly - For TNIO 360/390 as installed in Supplement Appendix

Item	Part Number	QTY	Description
1)	212-0046	1	Plate and Tube Assembly
2)	557-24	1	Phenolic block
3)	118-0003A	1	Shim
4)	212-0040A	1	Door
5)	308L-045	1	Safety wire
6)	333-04B	1	Bracket, Spring Attach
7)	557-20B	1	Bellcrank
8)	557-22B	1	Door Bracket
9)	8356A37	1	Magnet
10)	AN426A3-5	24	Rivet, Flat Head
11)	AN470AD3-5	2	Rivet
12)	AN470AD4-4	3	Rivet
13)	AN525-832-R6	1	Screw, Washer Head
14)	AN525-832-R7	12	Screw, Washer head
15)	AN960-416	2	Washer

Alternate Air Assembly - For TNIO 360/390 as installed in Supplement Appendix

Item	Part Number	QTY	Description
16)	AN960-8	4	Washer
17)	C81	1	Spring
18)	K1000-08	12	Nut Plate
19)	MS20001	1	Hinge
20)	MS21042-06	1	Stop Nut, Plated
21)	MS21042-08	4	Stop Nut, Plated
22)	MS21042-4	1	Nut
23)	<u>101-0050</u> MS24693-C32	1	<u>Socket head</u> Screw, Countersunk
24)	MS24693-S50	3	Screw, Plated
25)	<u>AN4-10A</u> MS24694-S103	1	<u>Bolt</u> Screw , Countersunk

S.3 Preparing for the Main Gear Installation

S.3.A Leveling the Fuselage

Steps...

1. Set the fuselage to level for pitch and roll.
Remember to rest the fuselage high enough to allow room for the gear legs. Allow approximately 32" from the floor to the bottom of the wing stubs.
Secure the fuselage in its level position.
2. Mark a center line on the floor. For more information on locating a center line, see Chapter 7, page 7-3 of the *Legacy Assembly Manual*. This will refresh your memory on drawing a center line.

Figure S.3.A.1 Leveling the fuselage



S.4 Installing the Gear Legs

S.4.A Positioning the Gear Leg

The top of the gear leg needs to be 50° from horizontal.

Figure S.4.A.1 Cross-section view of the gear leg angle

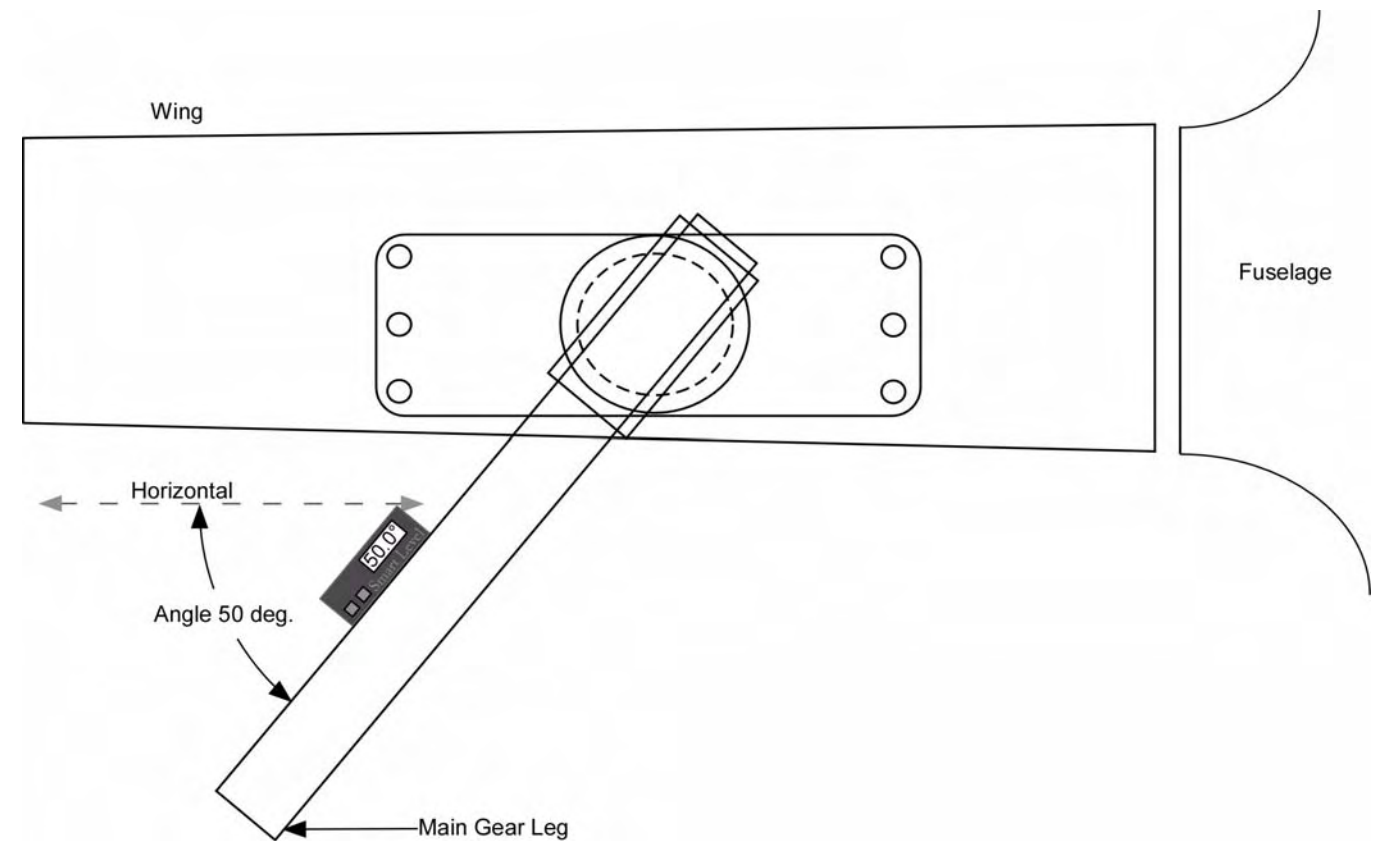

S.4.B Installing the Gear Leg

Steps...

1. Locate the upper-leg attachment on the inside of the forward wing spar. Position using the following guidelines:
 - Set as low as possible on the wing spar. Leveling may require up to two tongue depressors between the wing floor and the bottom of the upper-leg attachment on the inboard side.
 - Locate the inboard edge at 3" (75 mm) outboard from the inboard spar bolt hole in the forward wing spar. See the dimension location in Figure S.4.B.1.
2. Verify the position of the upper-leg attachment by testing the aileron push-pull tube for clearance. The aileron push-pull tube must clear the upper-leg attachment.
For information on the location and assembly of the aileron push-pull tube, see Chapter 6, Section B in the *Legacy Assembly Manual*.
3. Clamp the upper-leg attachment in place.
4. Cut the gear leg hole so it is large enough to slide the gear leg in place.
5. Insert the gear leg through the opening and into position in the upper-leg attachment. See Figure S.4.B.1.
6. Insert the bolt (AN4-22A) that holds the gear leg in place.

Figure S.4.B.1 Locating the gear leg opening and attaching the upper-leg attachment.

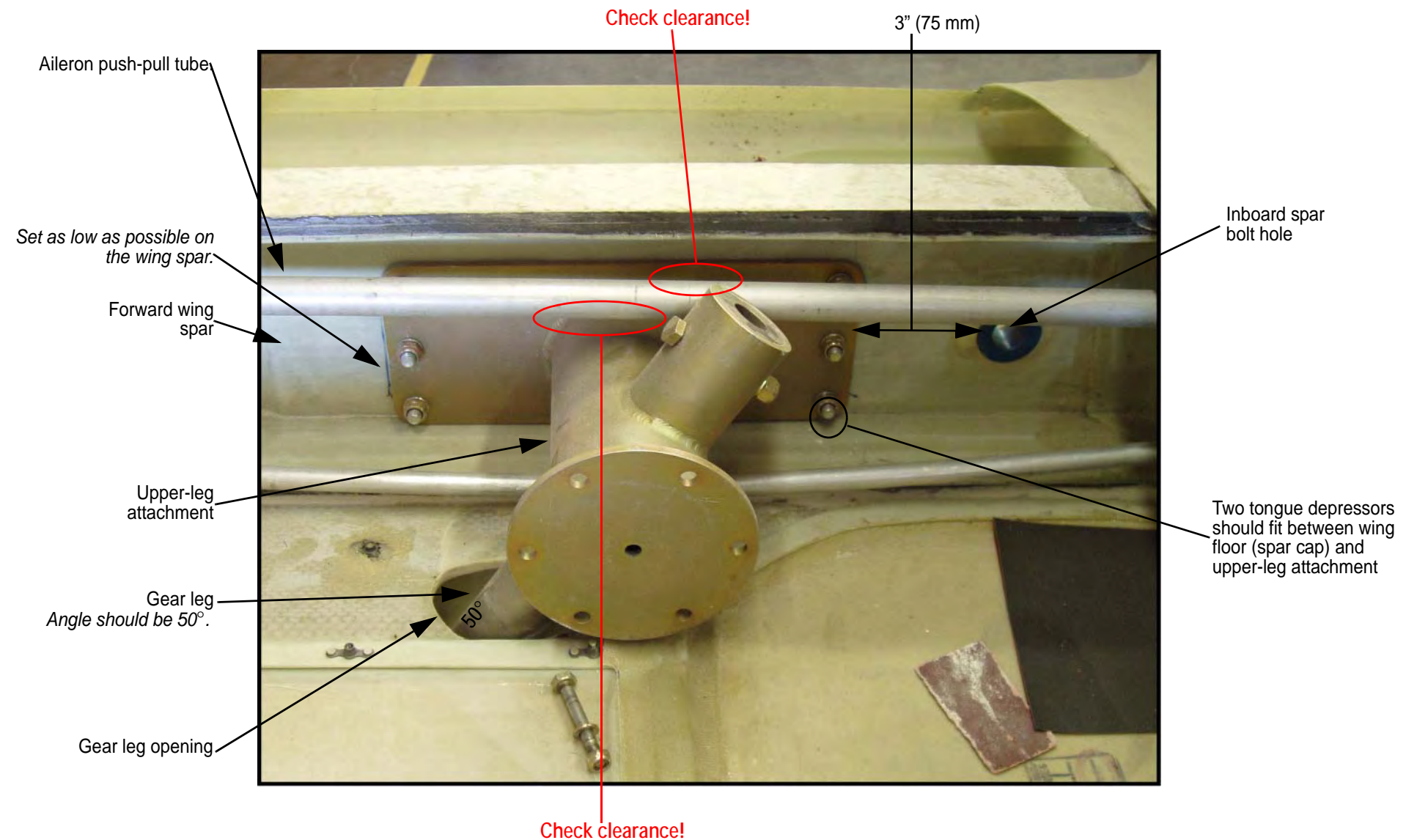

7. Check the angle of the gear leg.
 - Needs to be at approx. 50° from horizontal.
 - And, needs to be within $\pm 0.5^\circ$.
8. Adjust the position of the upper-leg attachment on the wing spar as needed to obtain the 50° angle and re-clamp.
9. Recheck the angle of the gear leg and make any necessary adjustments.
10. Back drill and install the screws that hold the upper-leg attachment in place.

Countersink from the front and insert a screw (MS24694-S154) in each hole.

Add a washer (AN960-516) to the back and secure with a nut (AN365-528A).

Now you are ready to install the gear leg.

Attaching the Gear Leg

You may have temporarily inserted the gear leg into the upper gear attachment in the previous section when you checked the angle of the leg, now you will finish the installation.

Figure S.4.B.2 Completed upper-leg attachment with gear leg

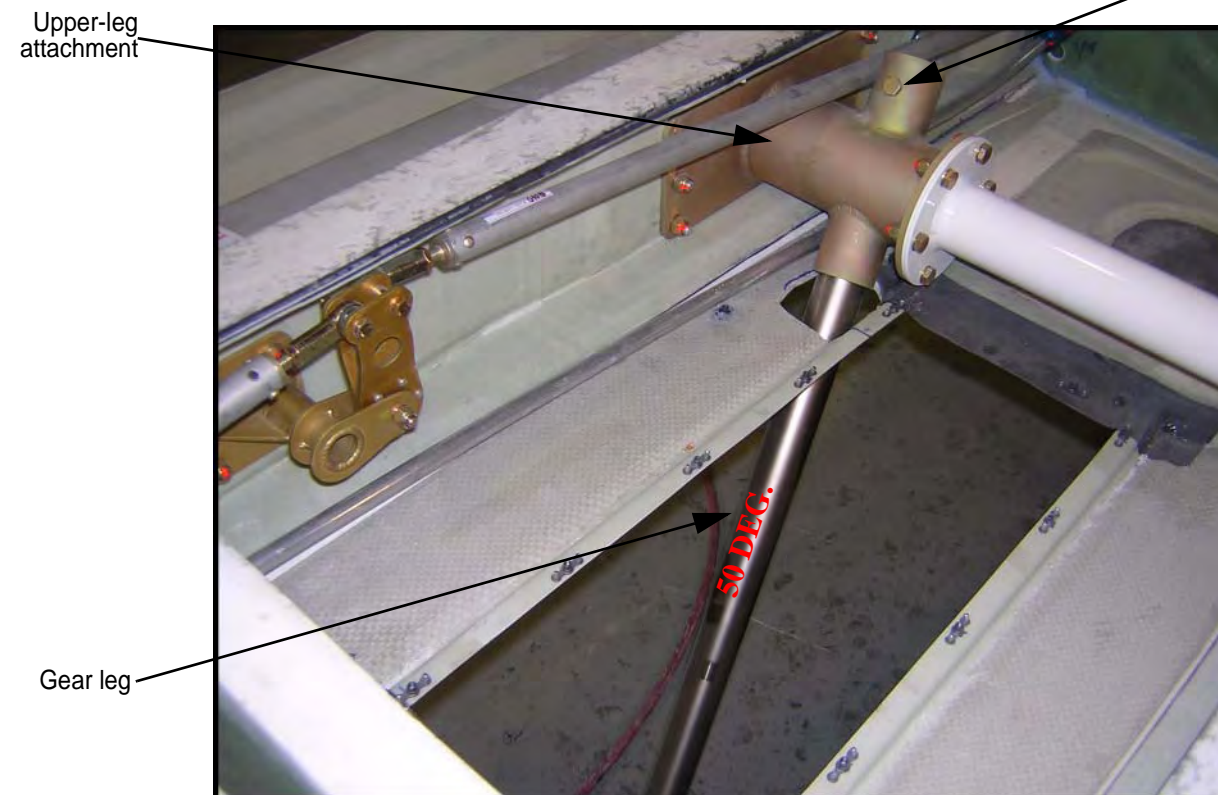

Installing the Gear Leg

The gear leg is already inserted into the upper gear attachment.

1. Insert a bolt (AN4-22A), from the top, through the sleeve and the gear leg.
2. Secure the bolt with a washer (AN960-416) and a locknut (AN365-428A).

Securing the Upper-Leg Link

Now you will finish installing the upper-leg assembly by installing the upper-leg link. First you need to determine the fit of the upper-leg link and complete a release before installing the remaining assembly.

See the next page for instructions.

Figure S.4.B.3 Securing the upper-leg attachment and link to the wing spar

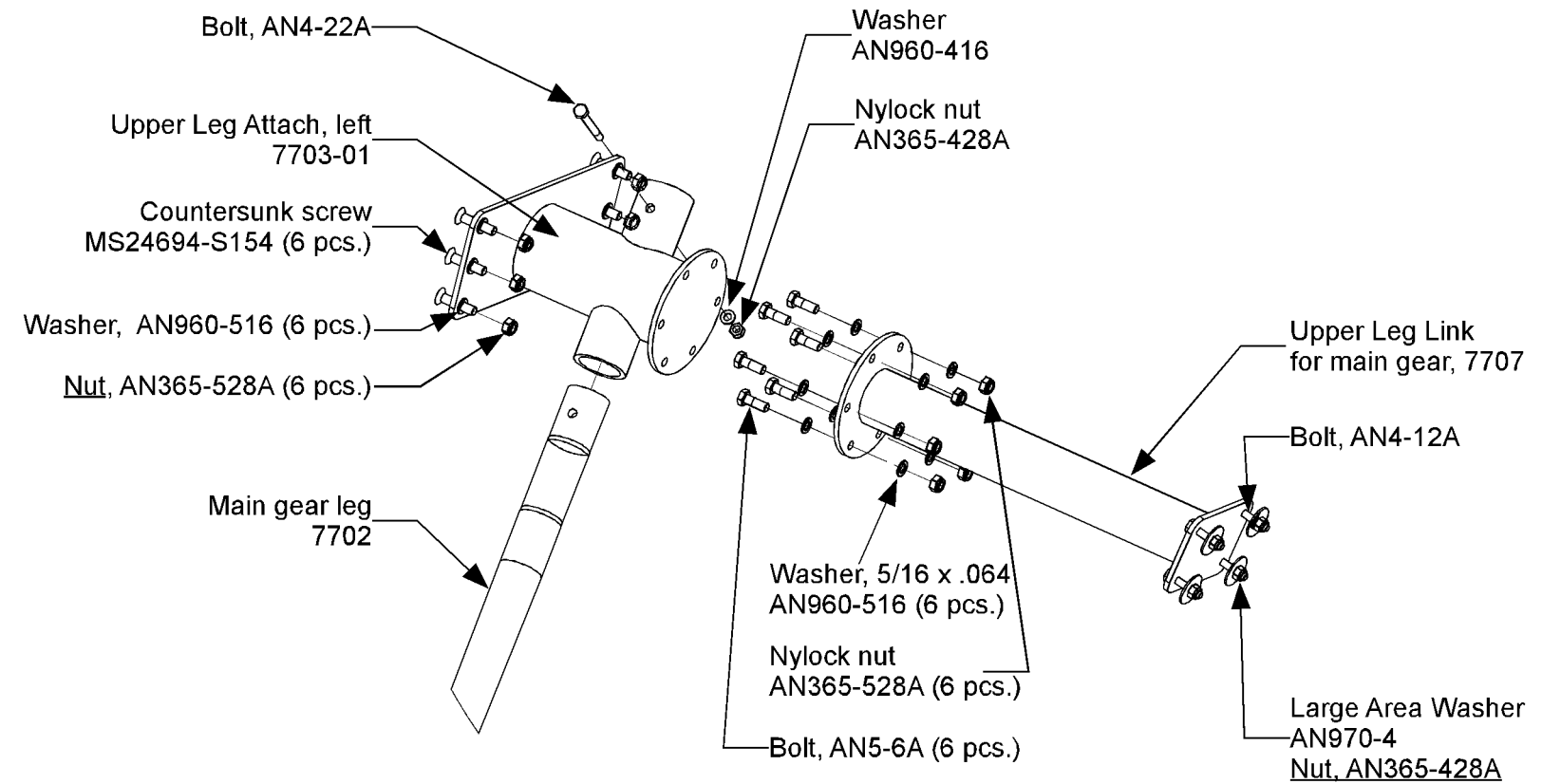

Steps...

1. Hold the upper-leg link (7707) in place against the upper-leg attachment.
2. Check the aft wing spar and determine how much of a release needs to be installed.
3. Tape the end of upper-leg link with clear tape. Add flox and set the link in place. Use a tongue depressor to create a clean fillet around the end of the link.
4. Install the six bolts that secure together the two sections of the upper-leg attachment. Secure each bolt.
5. From the inside, mark the four bolt locations for securing the upper-leg link's aft end to the inside of the aft wing spar.
6. Mark and back drill four holes.
7. Insert the four bolts from the inside and secure them on the aft outside of the wing stub.

Now you are ready to check the toe-in angle as described in the next section, *Setting the Toe-in* on page S.10.

Figure S.4.B.4 Upper-leg link held in place between upper-leg attachment and aft wing spar

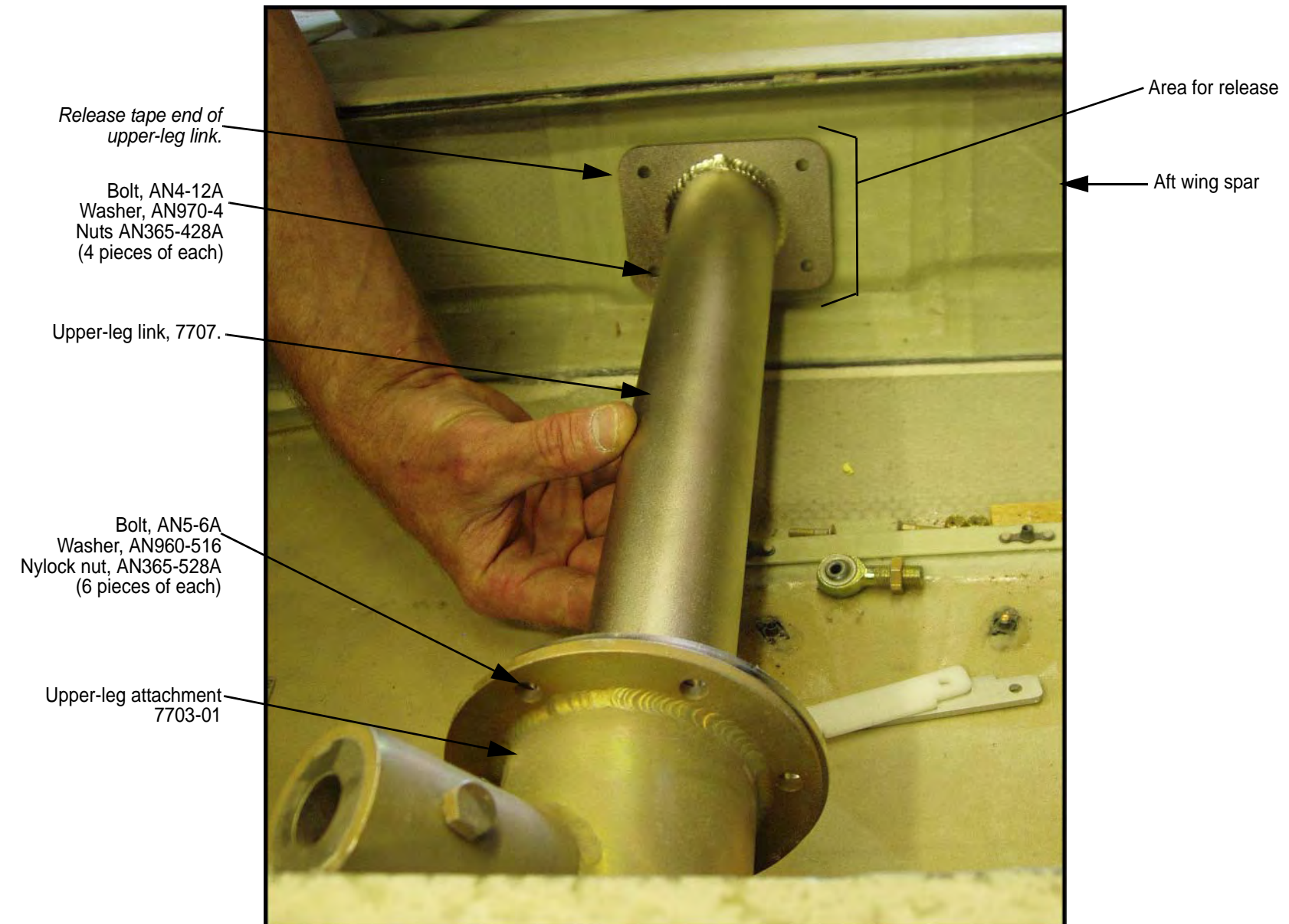

S.4.C Setting the Toe-in

In this section you will be setting the main gear's toe-in angle to 0.5°. We want to emphasize that the precision of this setting is extremely important for ground handling and tire wear.

Steps...

1. Attach the axle mount to the gear leg by slightly snugging the set screw.
2. Using the fuselage center line that you drew on the floor in *Leveling the Fuselage* on page S.5, find the location for the toe-in lines:

The toe-in lines must:

- Be parallel to the fuselage center line.
- Be directly below the alignment tool using a plumb bob as shown.
- Extend 3' (1 meter) in front of the gear leg.

3. Attach a 3.5' (1.25 meters) or longer alignment tool to the end of the gear leg.

Notice that the forward hole on the end of the axle mount has some slack and the set screw can be loosened and tightened as needed for leveling the alignment tool.

4. Hang a plumb-bob as shown in Figure S.4.C.2 and mark its position on the floor.
5. Make a mark on the alignment tool, 3' (1 meter) forward of the center of the end of the gear leg.
6. Hang a plumb bob at this spot. See Figure S.4.C.4 on the next page.

Note: This process can also be done using a laser level.

Figure S.4.C.1 Alignment tool

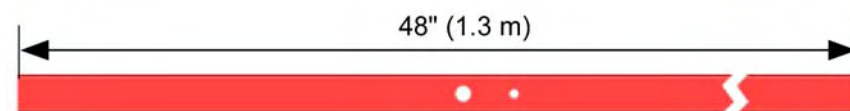
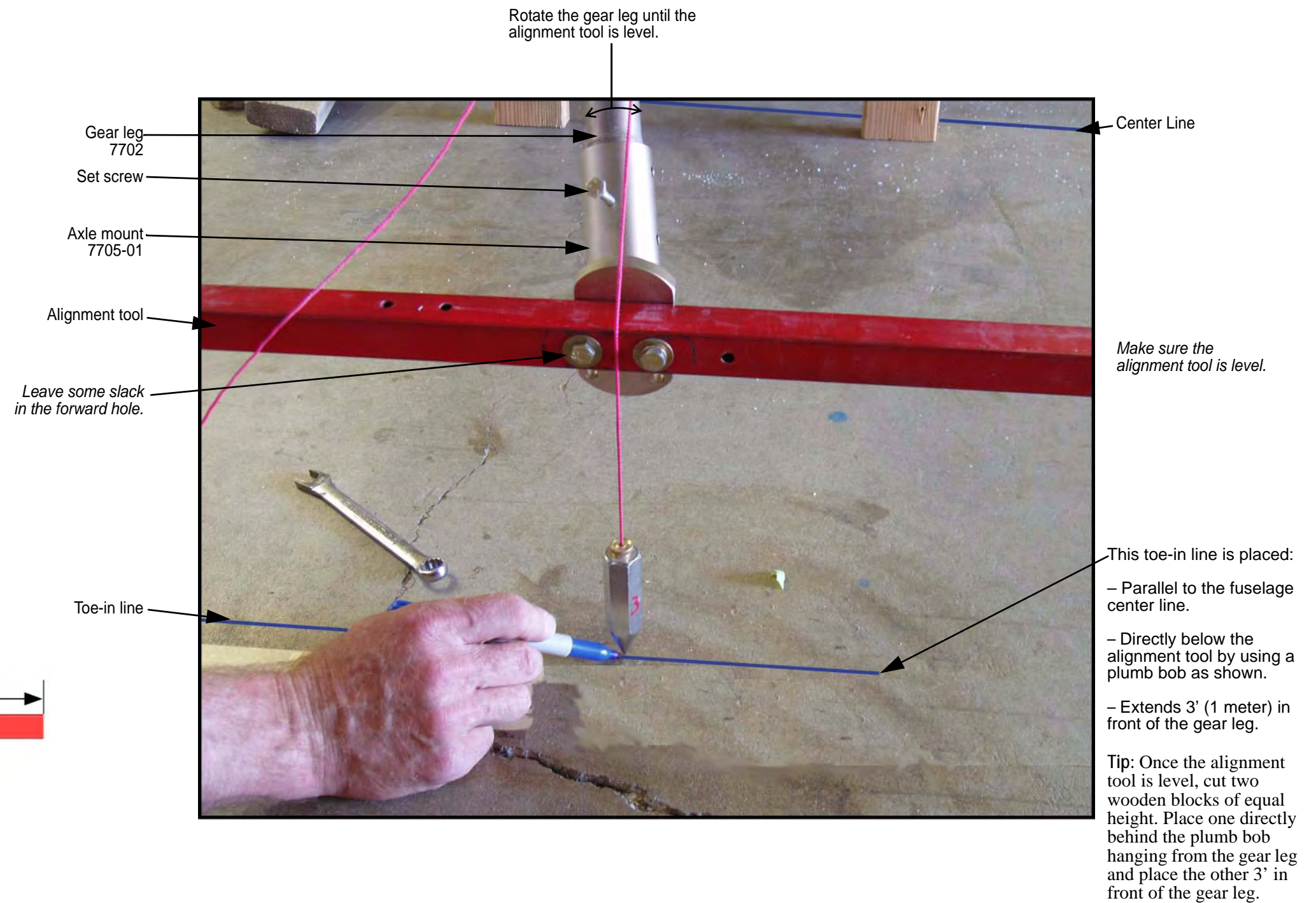

Figure S.4.C.2 Marking the gear leg location in relation to the toe-in base line



Again, make sure the alignment tool is level!

7. Mark the location of the plumb bob, at the 3' (1 meter) forward location.

8. Measure the distance from the toe-in line on the floor to the mark at the end of the plumb bob.

This distance needs to be 5/16" (8 mm). Or, in other words the toe-in needs to be 0.5°.

You may need to rotate the axle mount to get the correct amount of toe in. Do this by loosening the set screw, adjust as needed, and re-tighten the set screw. Now re-level the alignment tool.

Adjust as needed so the distance from the toe-in line to the plumb bob mark is 5/16" (8 mm) more at the 3' (1 meter) forward mark than the mark at the end of the gear leg.

Figure S.4.C.3 Top view of the gear legs, the lines on the floor and the alignment tools

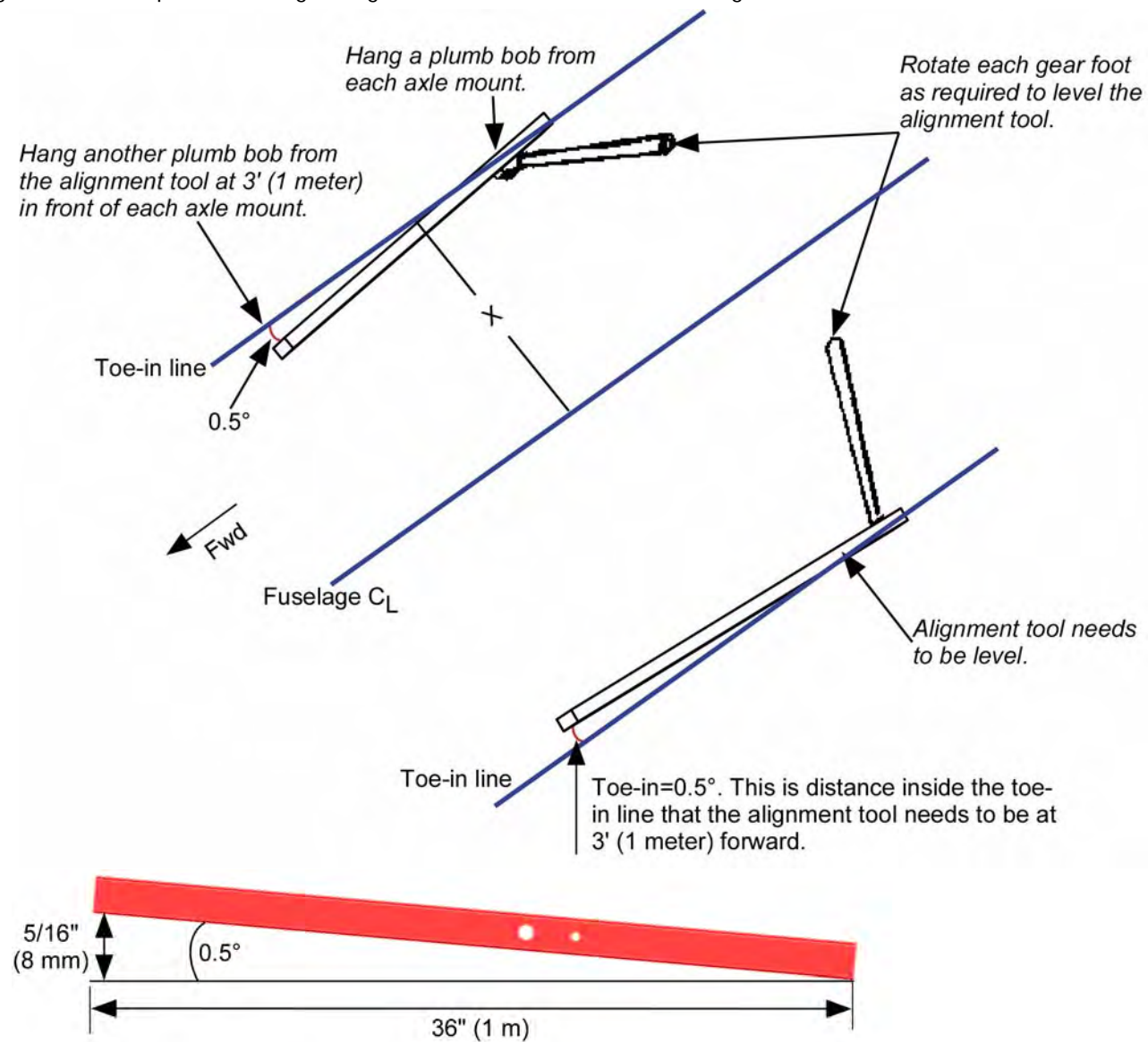

9. Re-check the dimensions.

- At 3' (1 meter) in front of the center of the axle mount, the plumb bob needs to be 5/16" (8 mm) inside the line on the floor.

10. Tighten all screws holding the gear leg and the alignment tool in place.

11. Re-check both plumb bobs, level the alignment tool and the toe-in angle.

Tip: If the alignment tool is not level, the toe-in angle will not be correct!

When you are satisfied that the toe-in angle is correct, you are ready to mark the bolt locations on the gear leg.

Figure S.4.C.4 Marking the second location at three feet in front of the gear leg

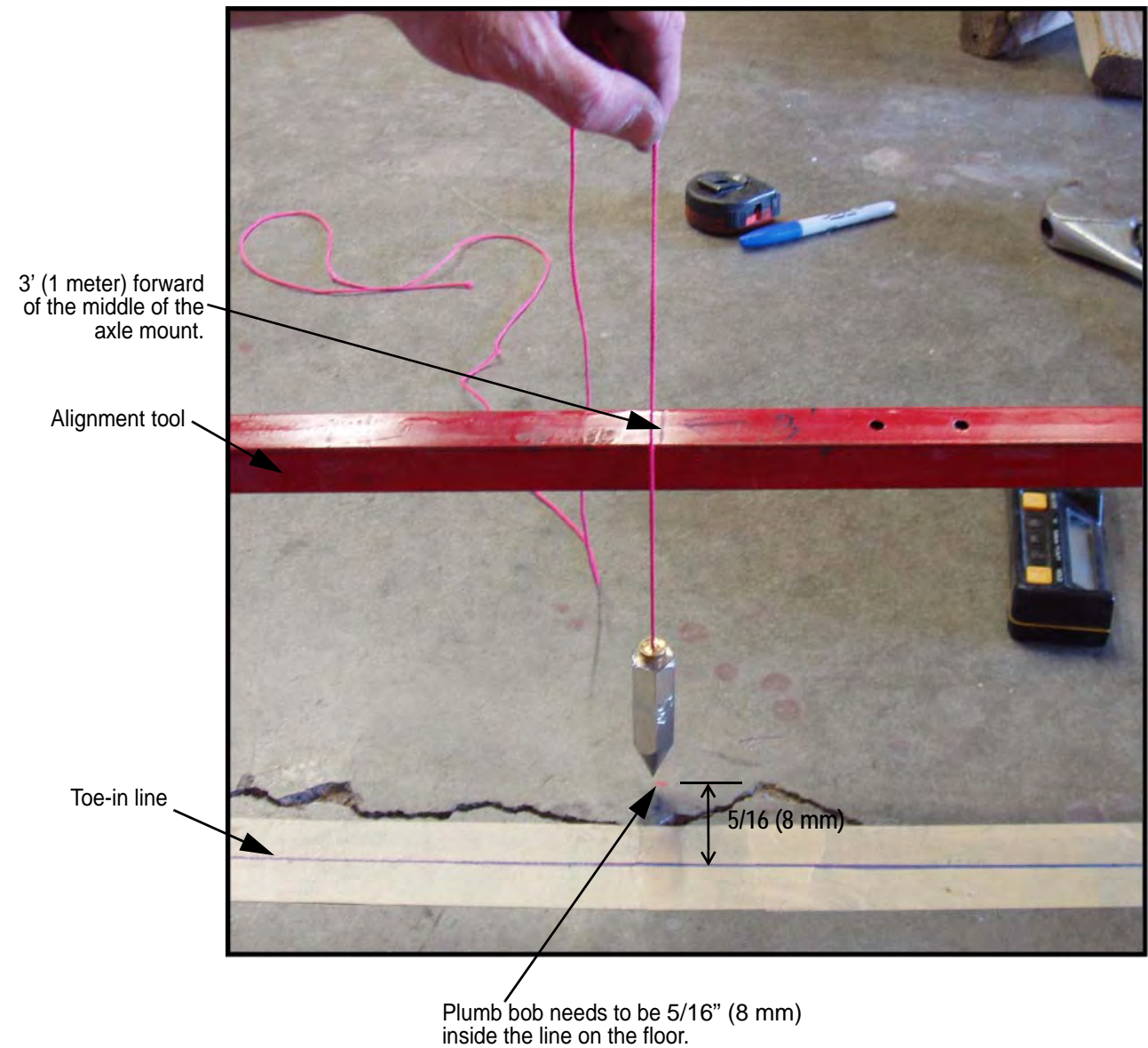

Securing the Axle Mount

Now that you have the gear leg correctly aligned, you are ready to secure the axle mount with the two bolts.

Steps...

1. Remove the gear leg with the axle mount attached.
2. Mark the bolt locations used to secure the axle mount using a drill bit or a transfer punch.
3. Create a small pilot hole in the gear leg, starting at 1/8" and enlarge to 1/4".
4. Using the pilot holes, drill the holes to final size with a 1/4" (6.3 mm) diameter drill. Drill the holes from both sides.

WARNING: Do not drill the holes all the way through from one side.

5. Slide a washer (AN960-416) over each of the bolts (AN4-20A).
6. Slide the bolts through the axle mount and the gear leg.
7. Secure the bolts with another washer (AN960-416) and a locknut (AN365-428A).

Figure S.4.C.5 Securing the axle mount to the gear leg

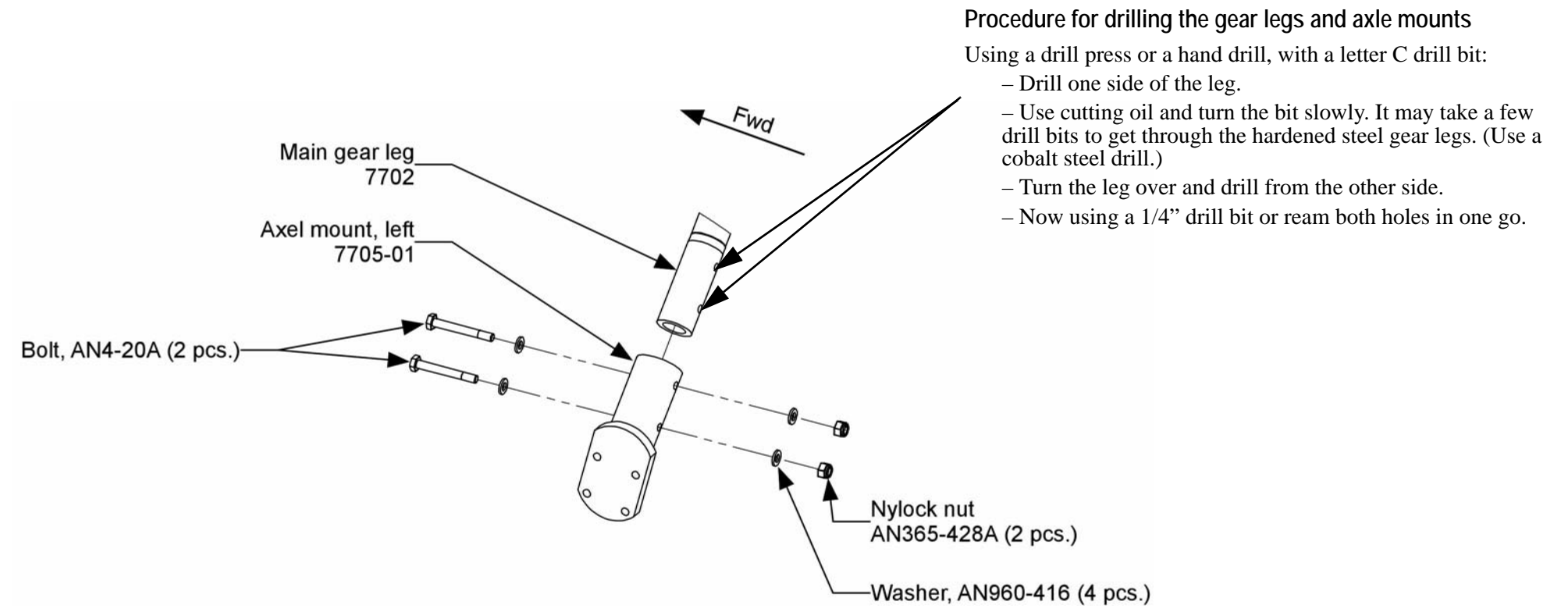

S.4.D Installing the Axle and the Wheel

In this section you will install the axle and attach it to the axle mount.

Installing the Axle

- Notice you are using two different bolts, AN4-12A in the top two holes and AN4-16A in the bottom two holes.

Figure S.4.D.1 Securing the axle mount to the gear leg

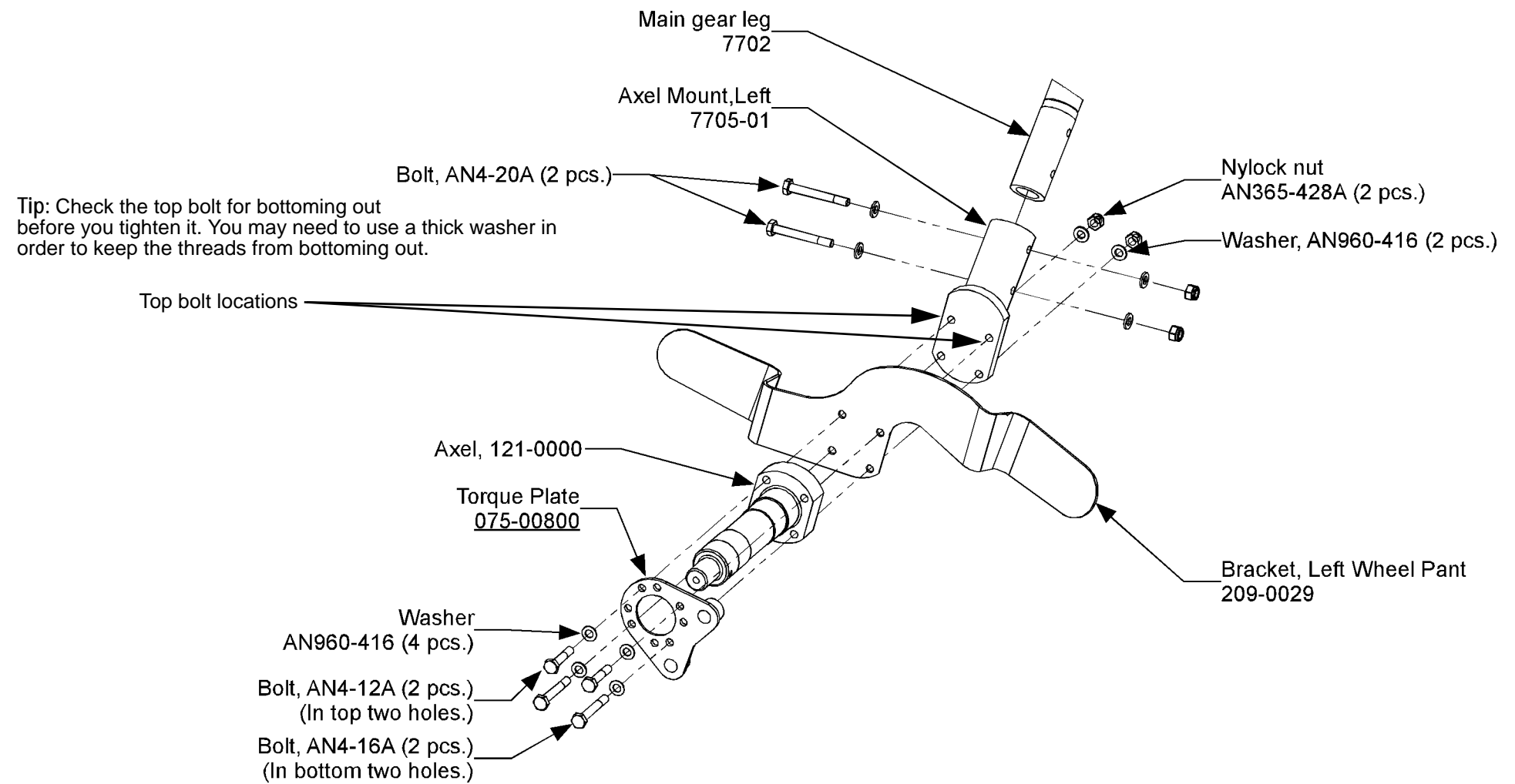

Assembling the Wheels and Tires

Securing the Wheels to the Axle

Use the *Legacy Assembly Manual* for the following installations:

- Installing the wheels to the axle as described on page 3-22.
- Installing the Cleveland Brake Assemblies.

Preparing for the Brake Installation

The following items must be complete before you can install the Cleveland brake assemblies.

- The brake discs must be secured to the wheels.
- The wheels must be mounted on the axle.

Refer to the *Legacy Assembly Manual*, page 18-3, to complete the brake installation.

Figure S.4.D.2 Securing the wheels to the axle

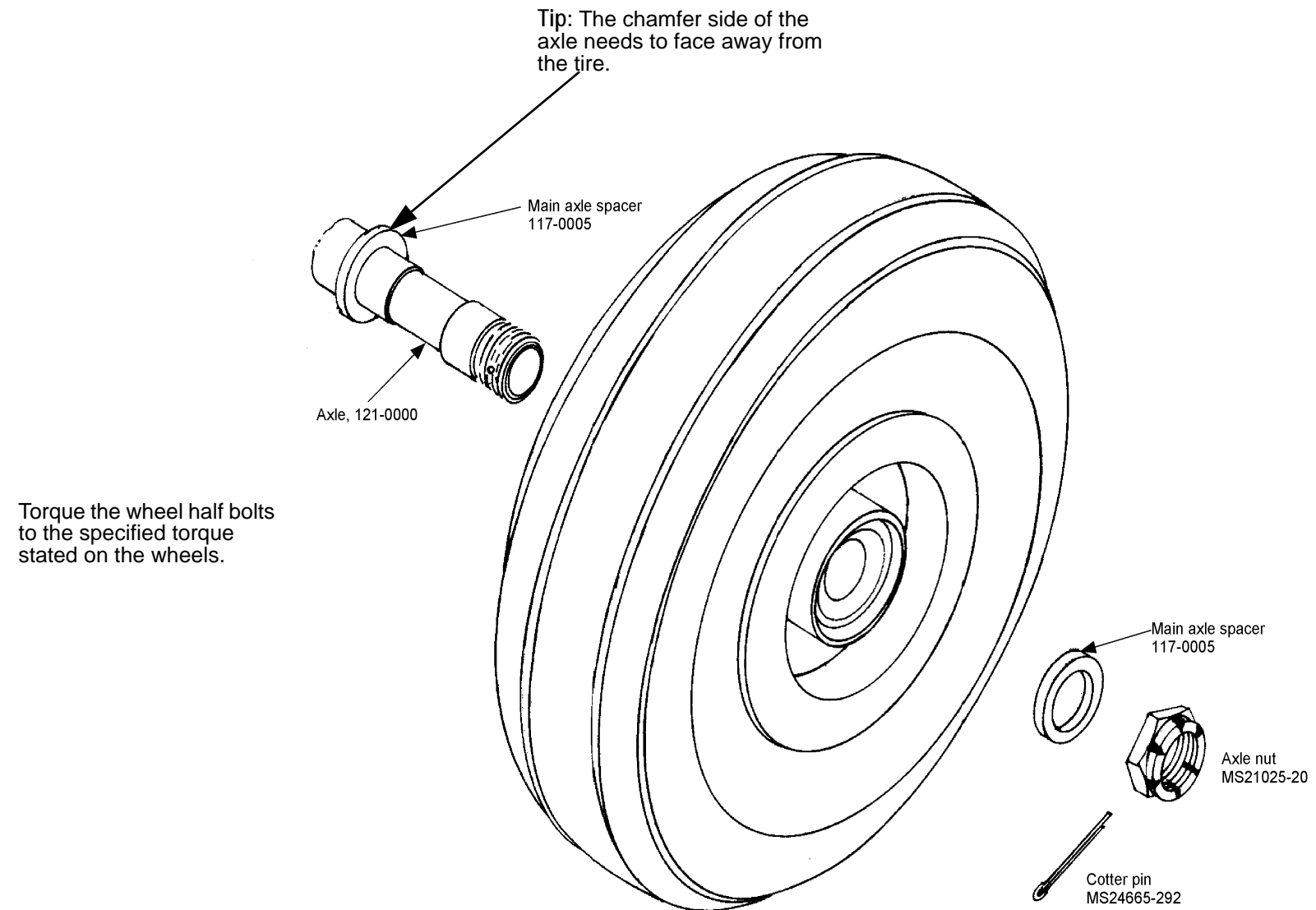

S.5 Installing the Main Gear Fairings

S.5.A Main Gear Fairings

The main gear is covered by fairings to reduce drag and to improve appearance. Each main gear is covered by three fairings.

Fitting Guidelines

- Always start with the wheel pant fitting and move up to the gear leg.
- The fairings and the wheel pant need to parallel the stream lines.
- The top of the gear leg fairing should fit in the contour of the fuselage gear fairing.
- The bottom contour of the gear leg fairing needs to fit the stem of the wheel pant.

It may be necessary to make some adjustments to get the fairings to fit smoothly.

Figure S.5.A.1 View of the Legacy Fixed Gear fairings

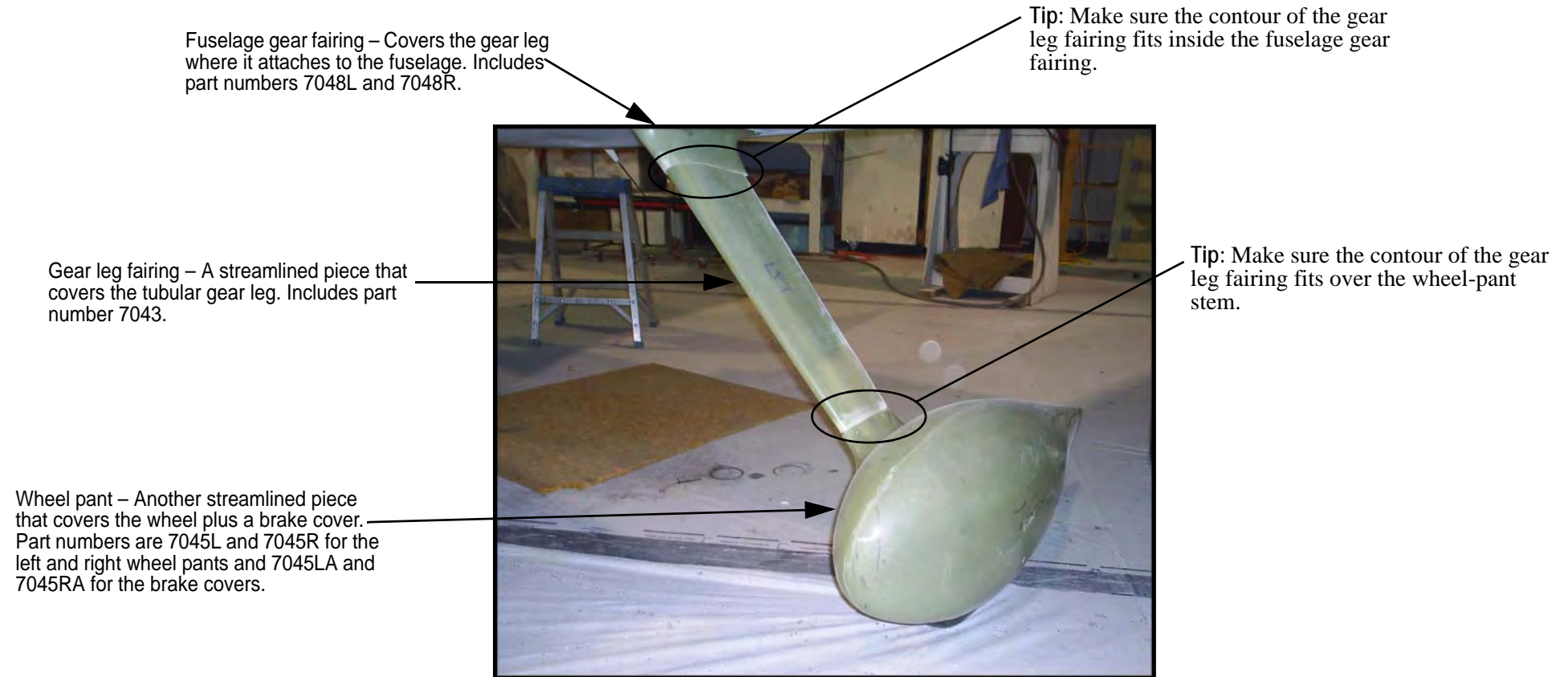

Gear Leg Fairings

There are two methods for completing the gear leg fairing.

Bonding – the bonding method is described below. If you use this method, the gear leg fairing must be in place before the axle is installed and the fairing cannot be removed without remove the axle mount.

– Or –

Hinged – split the back and use a piano hinge or nutplates to join the back joint. This method allows the fairing to be removed when necessary, without removing the axle mount and the brake assembly.

Steps...

1. Remove the peelply from the gear leg fairings and clean the molded side with Acetone.
2. Pre-fit the gear leg fairings to get an idea of how each one mounts.

Both the fuselage gear fairing and the wheel pant need to be pre-fit to the gear leg fairing. Match the contours where they meet the gear leg fairing.

Now you can either bond or hinge the aft side of the fairing.

Bonding Method Only

Bond the trailing edges of the gear leg fairings together with a thick epoxy/flox mixture. See Figure S.5.A.2.

- Sand the aft 1" of the inside of the gear leg fairing. Clean with Acetone and apply the epoxy/flox mixture.
- Clamp angle iron to the fairings to ensure a straight trailing edge.

While curing, the contour of the gear leg fairing should be matched to that of the fuselage gear fairing and the wheel pant. This will ensure the right shape for the gear leg fairing.

Figure S.5.A.2 Top-end view of the gear leg fairing

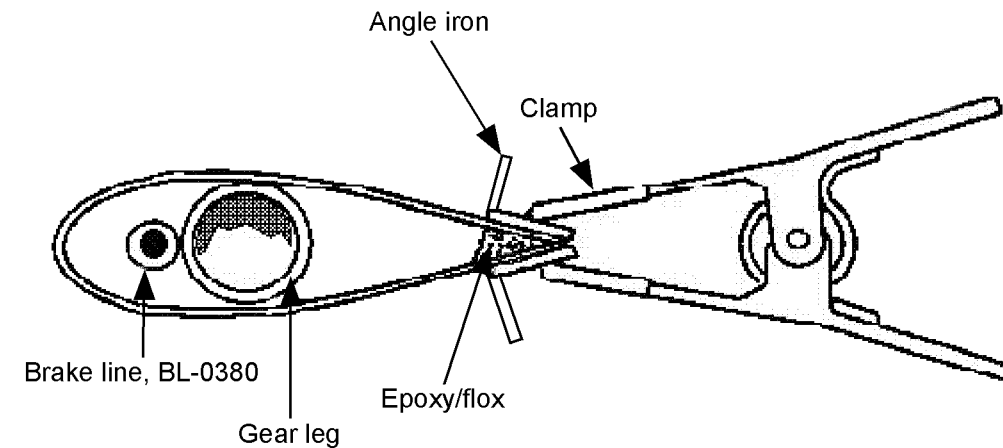

Tip: After the T.E. of the gear leg fairing is glued together, you will have to remove the axle mount to slide it off.

Note: This graphic applies to both methods of completing your gear leg fairings. Except that the bonding method of completion is the only method that uses epoxy/flox with the straight edge and a clamp.

Wheel Pants

In this section you will fit the wheel pant and attach the brake cover access panel that fits on the inboard side of each wheel pant.

Steps...

1. If the gap between the brake cover and the wheel pant access panel opening is uneven, clean it up with epoxy/micro.
2. Tape a 1/2" (15 mm) foam spacer to the top of the tire. This is to ensure adequate clearance between the tire and the wheel pant.

Trimming the Wheel Pant

The trimming of the wheel pant should be done concurrently with aligning it. If and when the bottom edge of the wheel pant is trimmed, the trimming should occur during the positioning and trimming for the axle bolt locating.

Trim to these guidelines:

- From the side, the bottom edge of wheel pant and the rim should be at the same level.
- When the plane is sitting on its gear, the tire must not hit the wheel pant.

Optional – Adding a Wheel-Pant Bulkhead

If you plan to land on unimproved airstrips, you will also need to add a wheel-pant bulkhead.

The purpose of the bulkhead is to prevent dirt and other debris from accumulating inside the wheel pant. The exact location is not critical, just ensure that there is adequate clearance between the tire and the bulkhead.

Steps...

- Install a wheel-pant bulkhead by cutting a piece to fit behind the tire in the aft section of the wheel pant. Use 2 PPS prepreg and secure with a 2" wide 2-BID on the front side.
- Drill a vent hole in the upper part of the bulkhead.

Figure S.5.A.3 Attaching the wheel pant

Wheel pant fits over the wheel and a brake cover is secured on the inboard side.

After the wheel pant is aligned, a bolt will slide through this location in the wheel pant to secure it to the axle. But first, you need to make a standoff of 1" to 1.5" (25 to 38 mm).

Nutplates, K1000-3 (3 pcs. per side of brake cover).

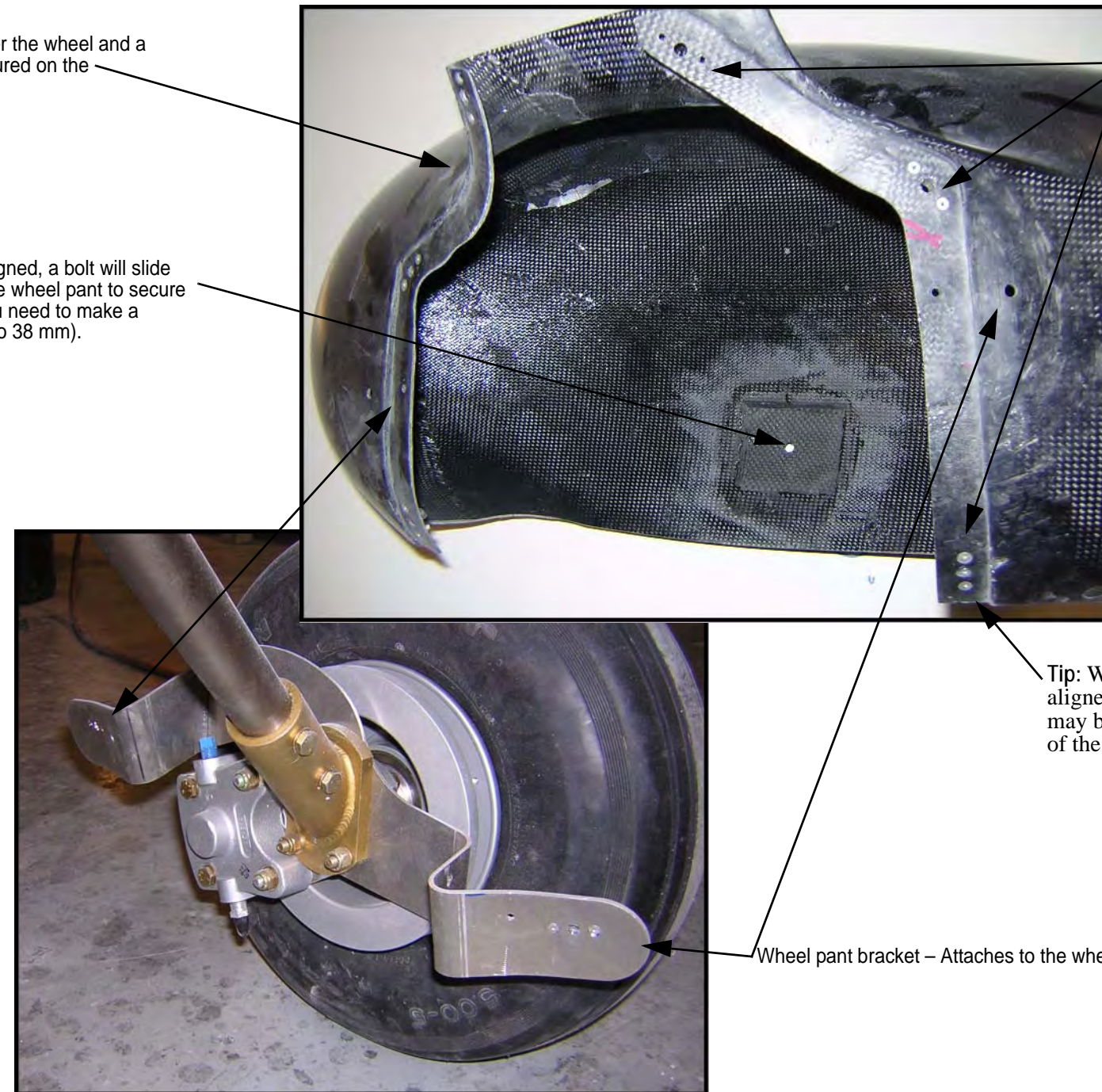

Tip: When the wheel pant is aligned on the next page, it may be necessary to trim areas of the bottom edge.

Wheel pant bracket – Attaches to the wheel pant.

Installing and Aligning the Wheel Pants

To install the wheel pants you need to jack up the aircraft. You may also want to put the gear leg fairing in place to check how the fairing pieces fit to each other.

Alignment Guidelines...

Align using the following guidelines:

- Tilt the wheel pant until it is approximately level.
- The wheel pant's center line should be parallel to the aircraft's center line.

The easiest method of accomplishing this is to draw a line on the floor showing the center line of the wheel. Then simply sight from above the wheel pant and align the wheel pant to the center line. You can also use the fuselage center line for aligning the wheel pant.

The fairings should be level and straight when the aircraft is in flight.

Figure S.5.A.4 Main wheel pant alignment



Bottom edge of the wheel pant and the edge of the wheel rim should be aligned (at the same level).

Trim as necessary all the way around the bottom edge of the wheel pant.

Bend bracket tabs or do a flox release (or both) to make the bracket and wheel pant connect. Then secure the wheel pant to the bracket using #10 crews and nutplates.

Place the wheel pant in position by:

- Jack up the plane.
- Slide the front over the bracket and wheel.
- Next slide the rear of the wheel pant back and down into place.

The wheel pant should be in a horizontal position as you proceed to align it.

Tip: When the plane is set back on the floor, roll it back and forth to allow the gear to relax into its normal position.

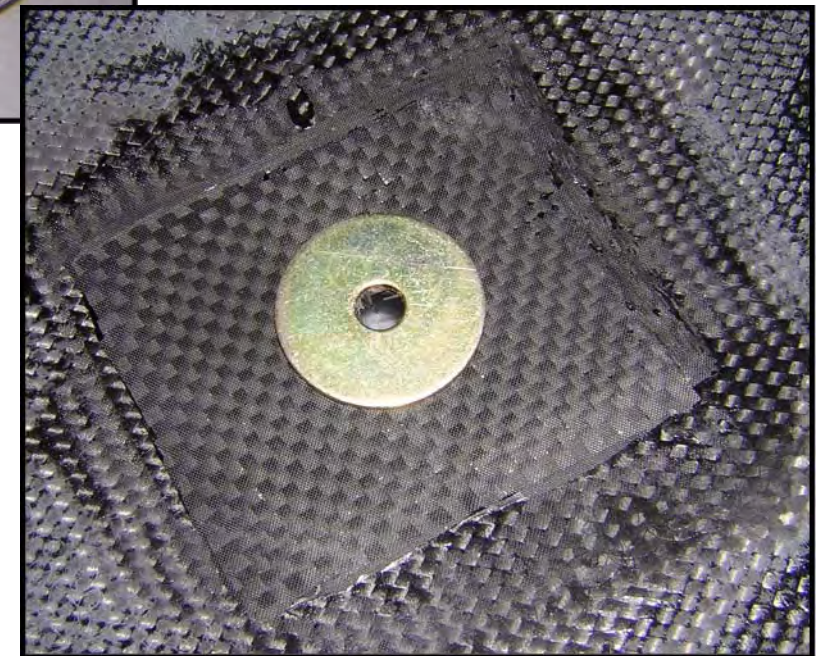

Outboard side of wheel pant.

Steps....

1. Cut the head off and sharpen the shank of an appropriate length AN4 bolt.
2. Screw the bolt into the axle under the wheel fairing.
3. Align the wheel pant using the *Alignment Guidelines...* instructions.
4. When the wheel pant is positioned set the bolt location by tapping the side of the wheel pant so the bolt you placed in the axle leaves an indentation on the inside of the wheel pant.
 - The washer and standoff set the inboard/outboard alignment of the wheel pant.
5. Drill out the resulting hole.
6. Cut the bushing to match the gap between fairing and axle.
7. On the inboard side, match drill through the wheel pant and the bracket.
8. Install nutplates in the resulting holes in the bracket.

Final Mounting of the Wheel Pants and Brake Cover

 The wheel pants must be aligned before they are mounted. See *Installing and Aligning the Wheel Pants* on page S.18.

Steps...

1. Install a AN4 bolt on the outboard side of the wheel pant using the following steps:
 - Sand the area washer with 40-grit sandpaper.
 - Sand the inside of the wheel pant around the hole you drilled out with 40-grit sandpaper.
 - Clean all the sanded areas.
 - Bond the area washer in place and reinforce with 2-BID.
 - Install the aluminum standoff, the outside washer and the AN4 bolt.
2. Countersink the brake cover for the MS24693-S28 screws.
3. Install six nutplates, three (K1000-3) along both the forward and aft edges of the flange on the wheel pant. These will be used later for securing the brake cover.

Figure S.5.A.5 Nutplate locations for wheel pant cover



Install six nutplates, three on each side of the gear leg, to secure the wheel pant cover.

Figure S.5.A.6 Front view of the wheel pant

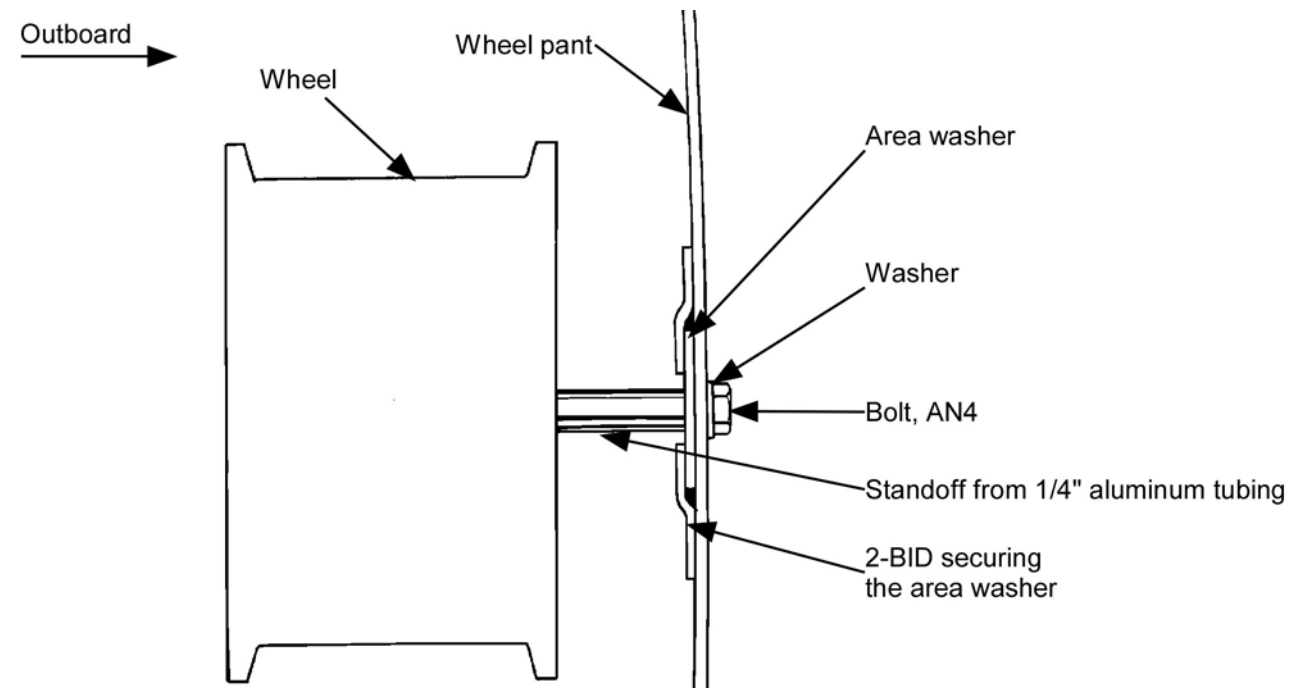

Tip: Make sure the contour of the gear leg fairing fits over the wheel-pant stem.



S.5.B Fuselage Gear Fairings

The fuselage gear fairing is fitted and later screwed to the fuselage. The gear leg fairing and the wheel pant must be in place on the main gear before the fuselage gear fairing can be fitted.

Steps...

1. Fit the fuselage gear fairing by aligning it with the gear leg fairings.

The gear leg fairing should fit inside the fuselage fairing.

2. Trim the fuselage gear fairing piece as necessary in order to fit snugly against the bottom of the fuselage.
3. Drill holes and install -8 nutplates approximately every 3" (75 mm) in the wing core.

Or you may bond the nutplates in place using bondable nutplates or something similar to the detail in the figure below.

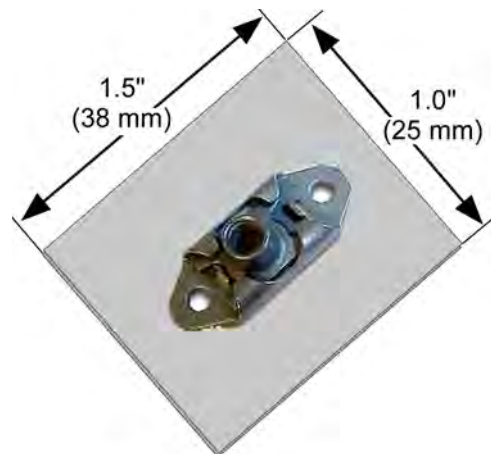

Nutplates can be riveted to BID strips of e-glass approximately 1.0" by 1.5" (25 mm by 38 mm).

Figure S.5.B.1 Fitting the fuselage gear fairings

WARNING: Before you drill, make sure you will not be drilling through any structural part such as the spar.

Fuselage gear fairing – Covers the gear leg where it attaches to the fuselage. Includes part numbers 7048L and 7048R.

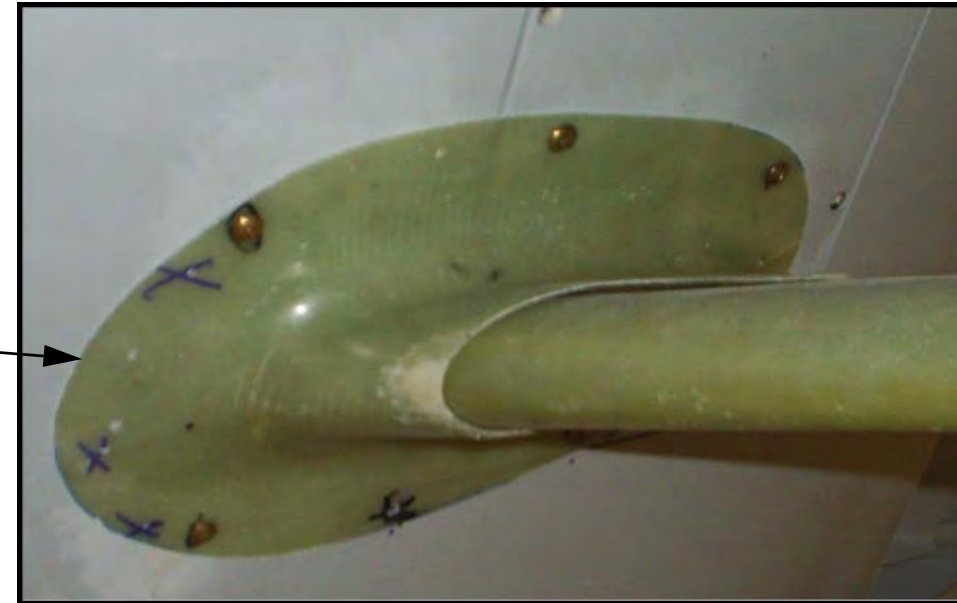

Figure S.5.B.2 Completed main gear fairings



S.6 Installing the Nose Gear

Remember to refer to the *Legacy Assembly Manual* for the *Nose Wheel and Tire* instructions in Chapter 13.

S.6.A Installing the Nose Gear Strut

- As stated on page 13-13 in the *Legacy Assembly Manual*, the strut should have a 0° to 3° forward rake.
- The profile of the pivot bearing blocks do not necessarily align with the cheek plates they are bolted to. See page 13-12 in the *Legacy Assembly Manual* or the Tip on page 1.23.

Figure S.6.A.1 Installing the nose gear strut

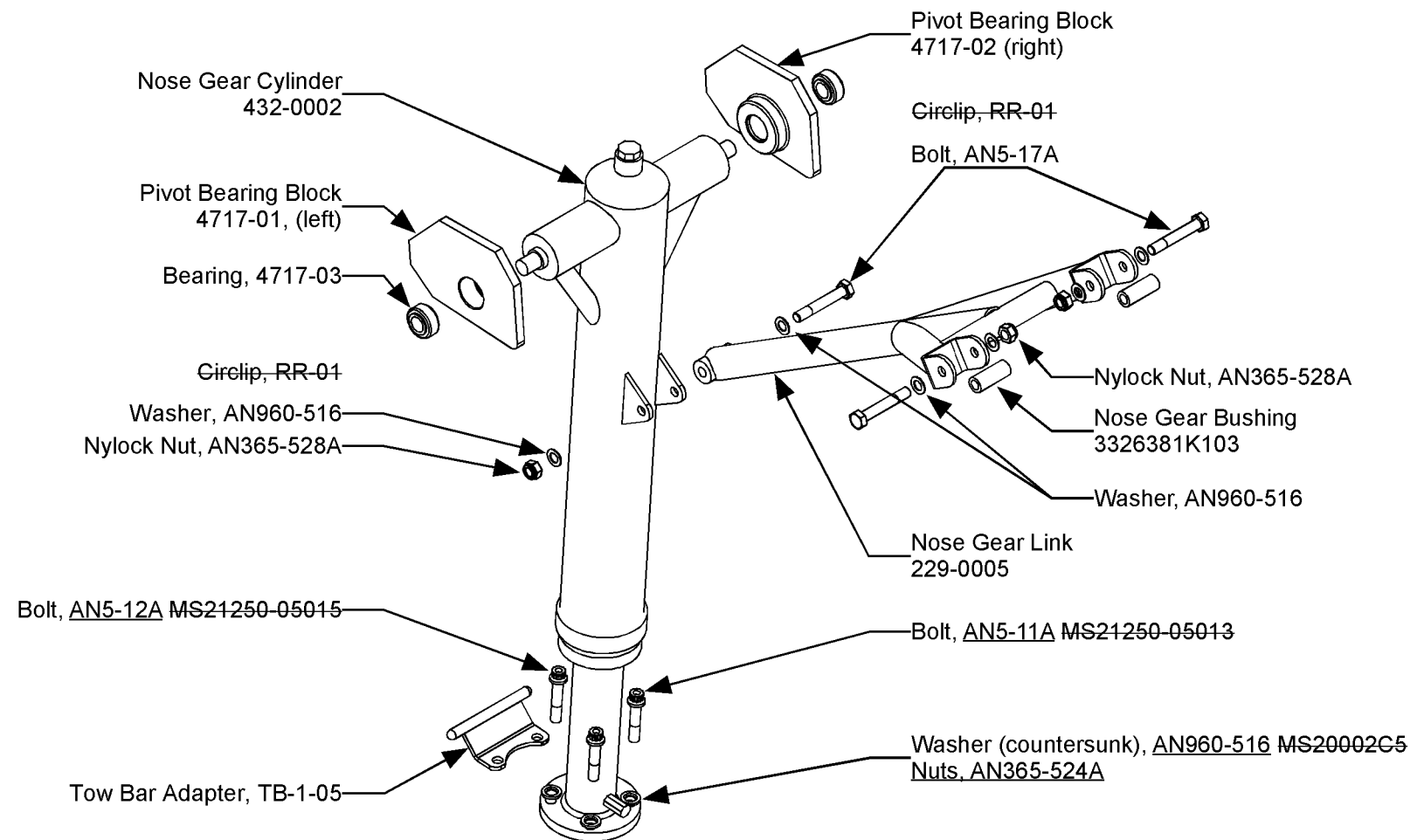
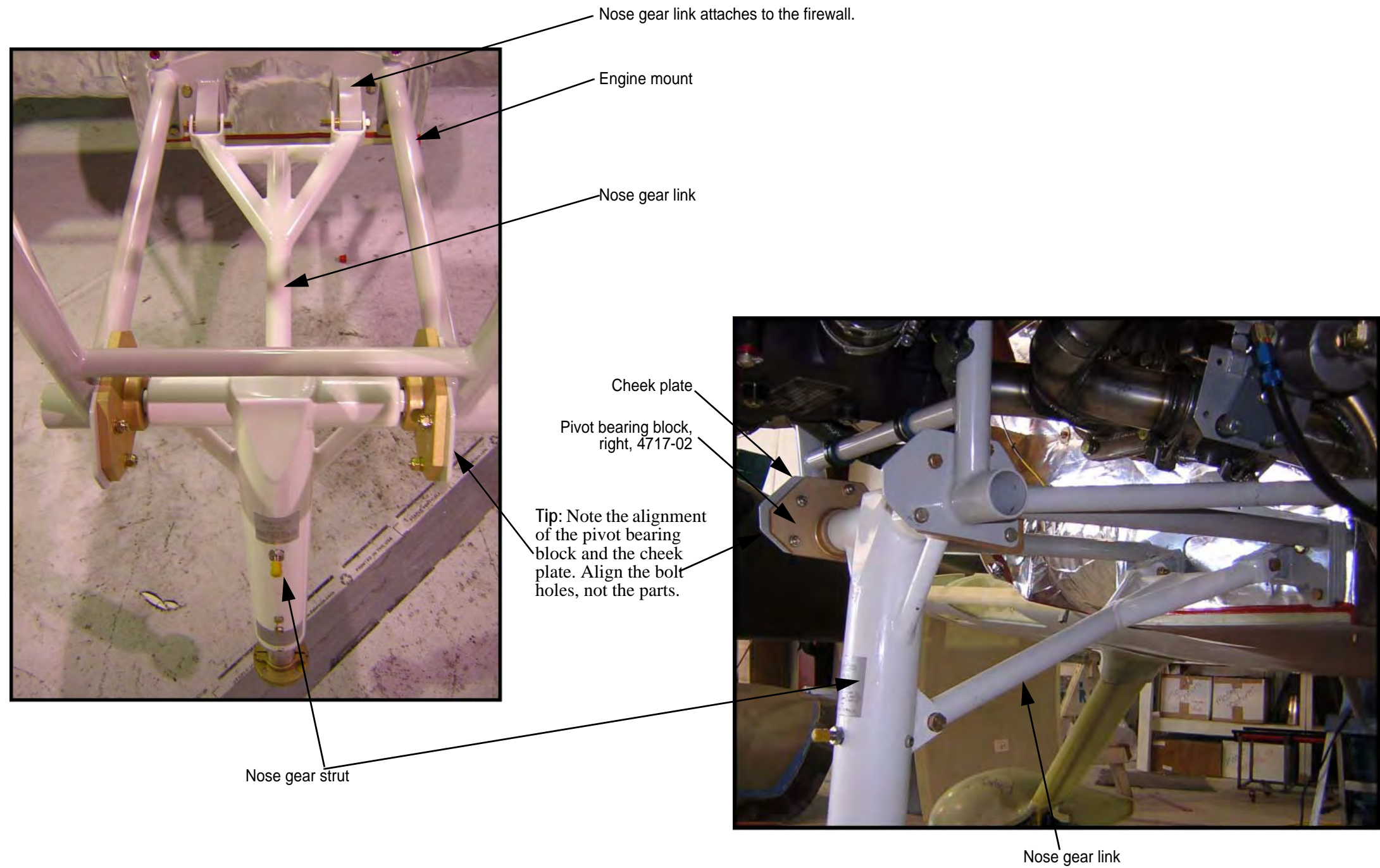

Figure S.6.A.2 Two views of an installed nose gear cylinder and nose gear link



S.6.B Connections Between the Nose Gear Fork and Wheel Bracket

Tip: It is important that the four washers, MS20002C5, are countersunk. Also make sure that the countersunk side is facing up with the strut is attached to the nose fork. This will allow for the radius and fillet of the bolt heads.

Figure S.6.B.1 Installing the nose gear fork

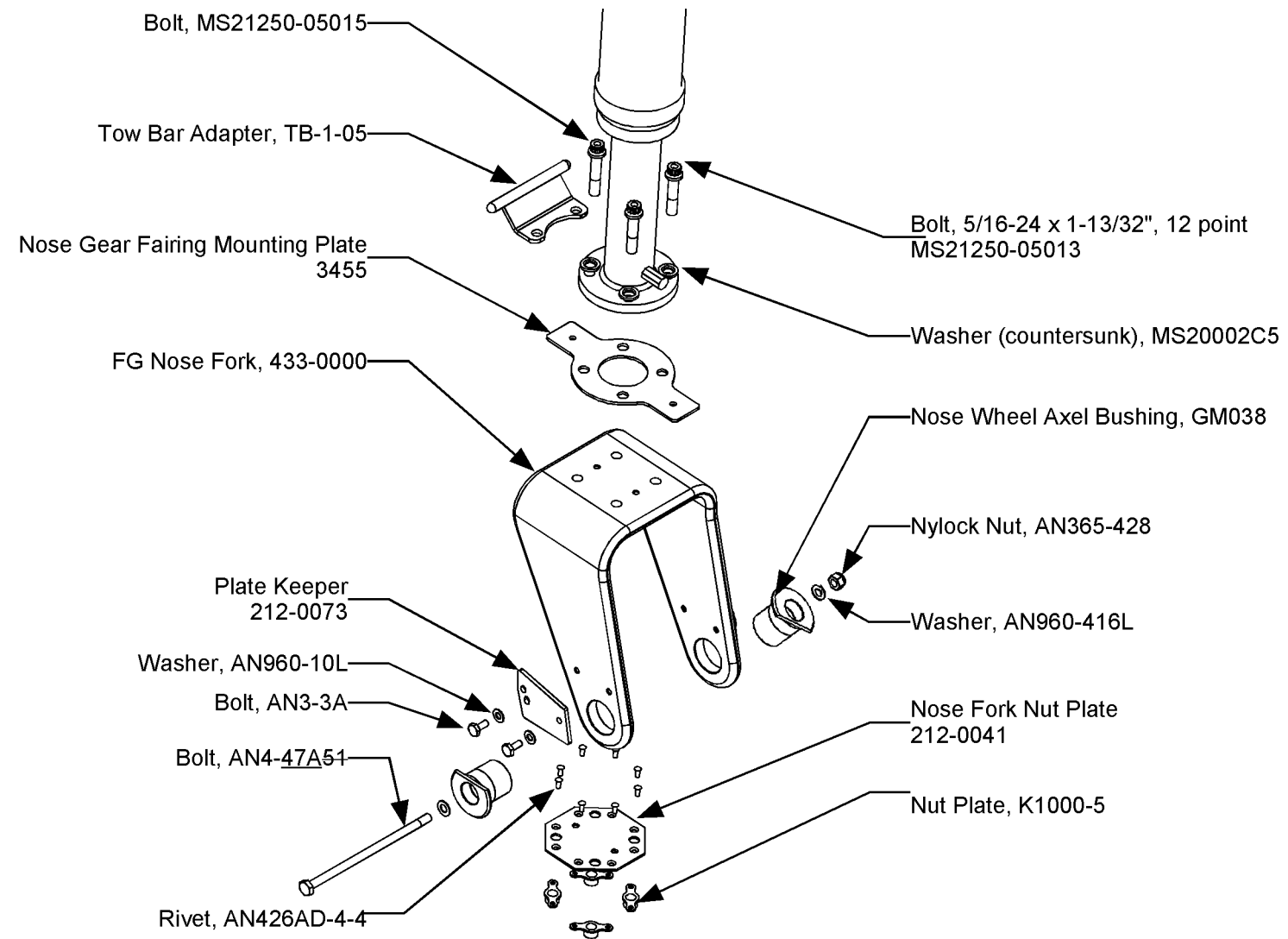

S.6.C Assembling the Nose Wheel and Tire

For more information on assembly of the nose tire and wheel, see the Legacy Assembly Manual, page 13-16.

Figure S.6.C.1 Nose Wheel Assembly

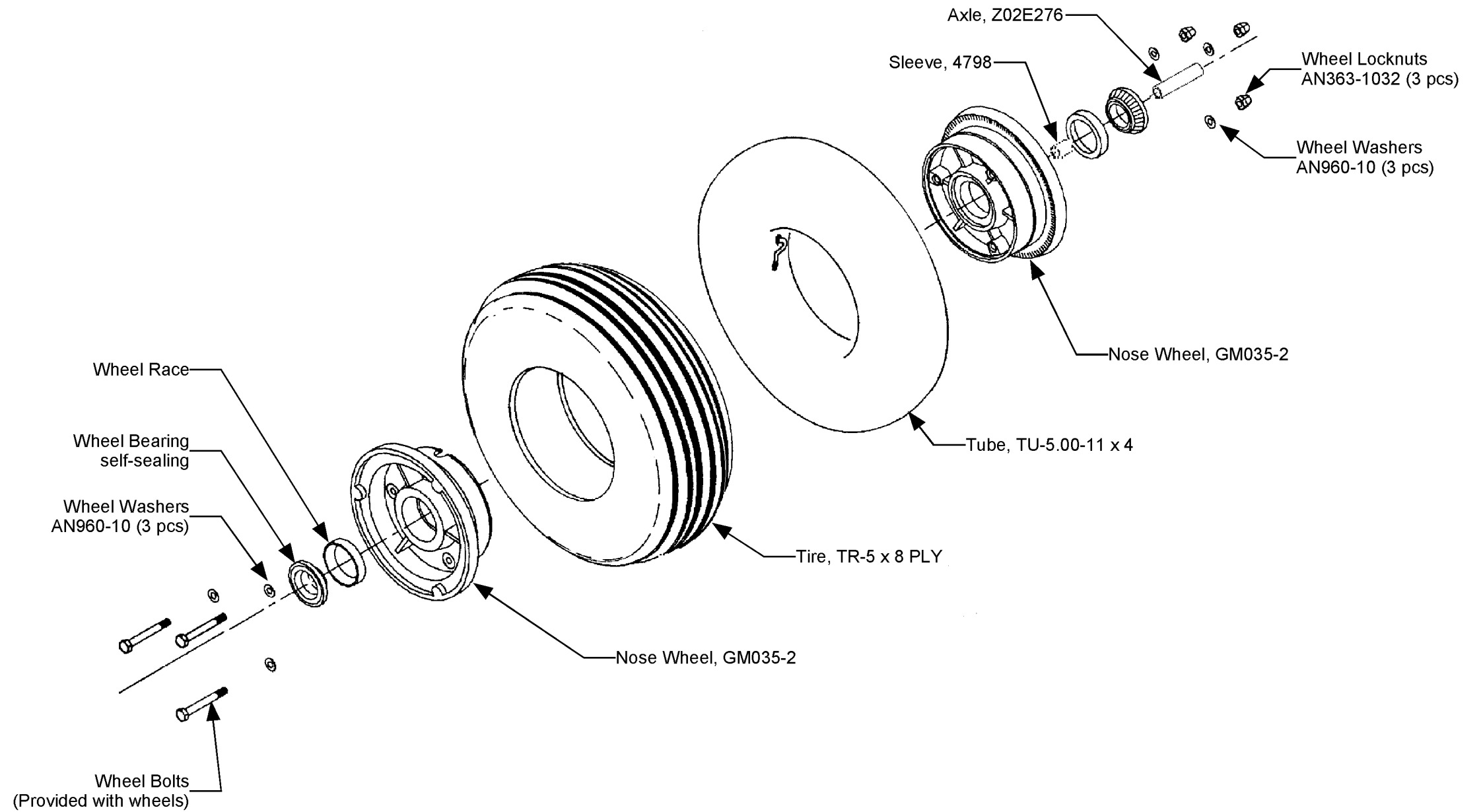

Figure S.6.D.1 Installing the nose-fork nut plates

S.6.D Installing the Nose Gear Fork

Refer to the *Legacy Assembly Manual*, Chapter 13 for the *Nose Wheel and Tire* instructions. All the part names and numbers are included in the diagram for the *Nose Wheel Assembly*, Fig. 13:E:1.

Use the figures to the right to install the nutplates on the nose fork.

Cut the head off an AN bolt to assist in the assembly to the fork and nose-wheel fairing. This altered bolt will act as a guide pin.

Install four nutplates, K1000-5, using rivets AN426AD-4-4.

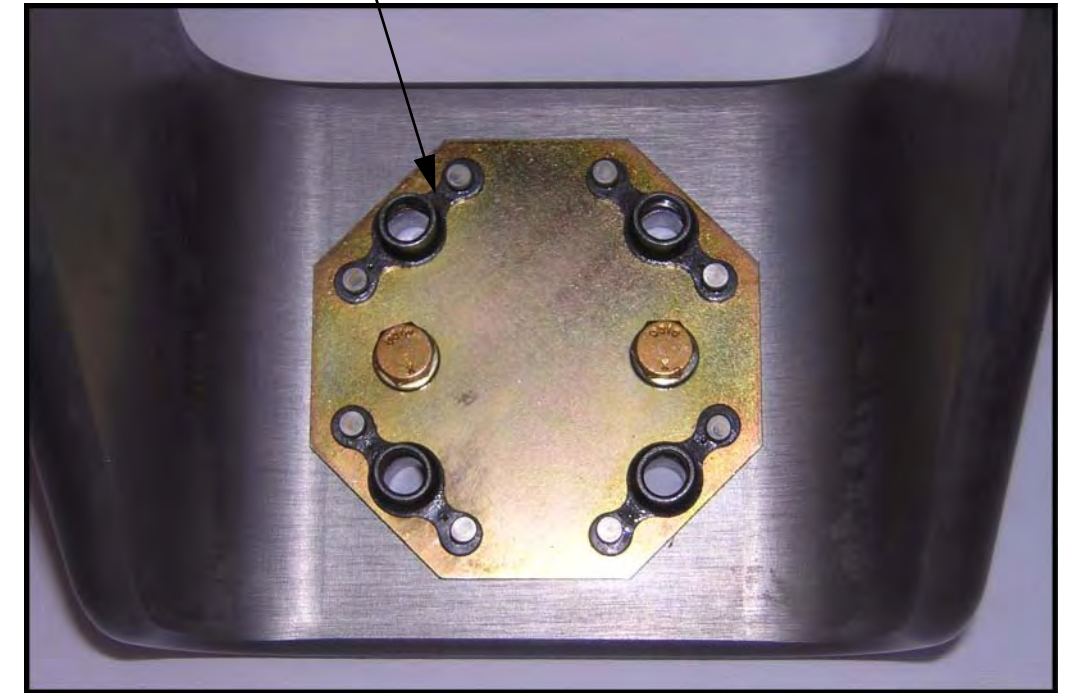
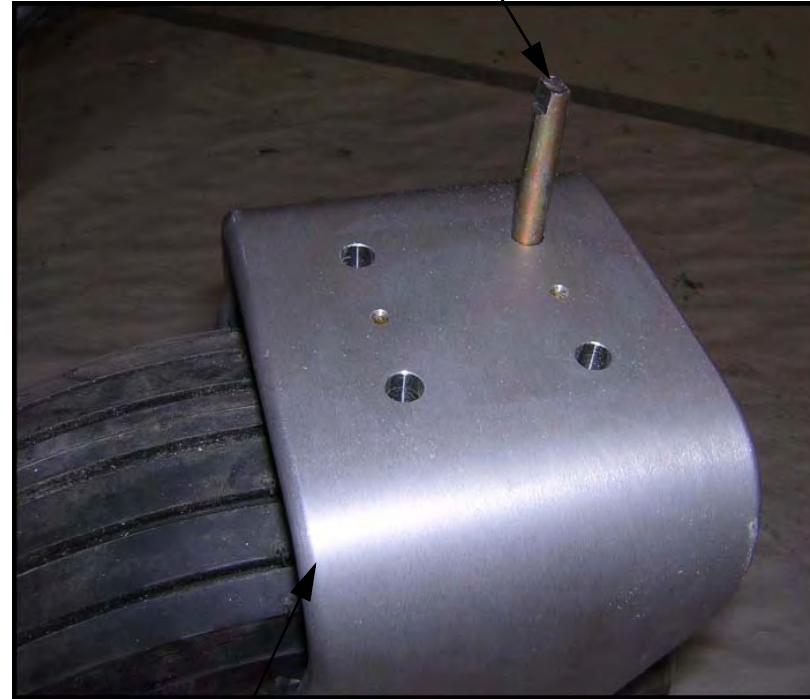

FG nose fork, 433-0000



AN525-10R6

S.6.E Installing the Nose Gear Mounting Plate

Use the following positioning guidelines for the mounting plate and the nose gear fairing.

Locating the Mounting Plate

- The fairing mounting plate needs to be installed on the center line of the nose gear fairing.
- From the center of the mounting plate to the aft end of the nose gear fairing should be approximately 21" (52.5 mm).

Positioning the Nose Gear Fairing

- The wheel pant needs to be level.
- From the side the wheel pant needs to be level with the ground.

Figure S.6.E.1 Installing the nose gear fairing mounting plate

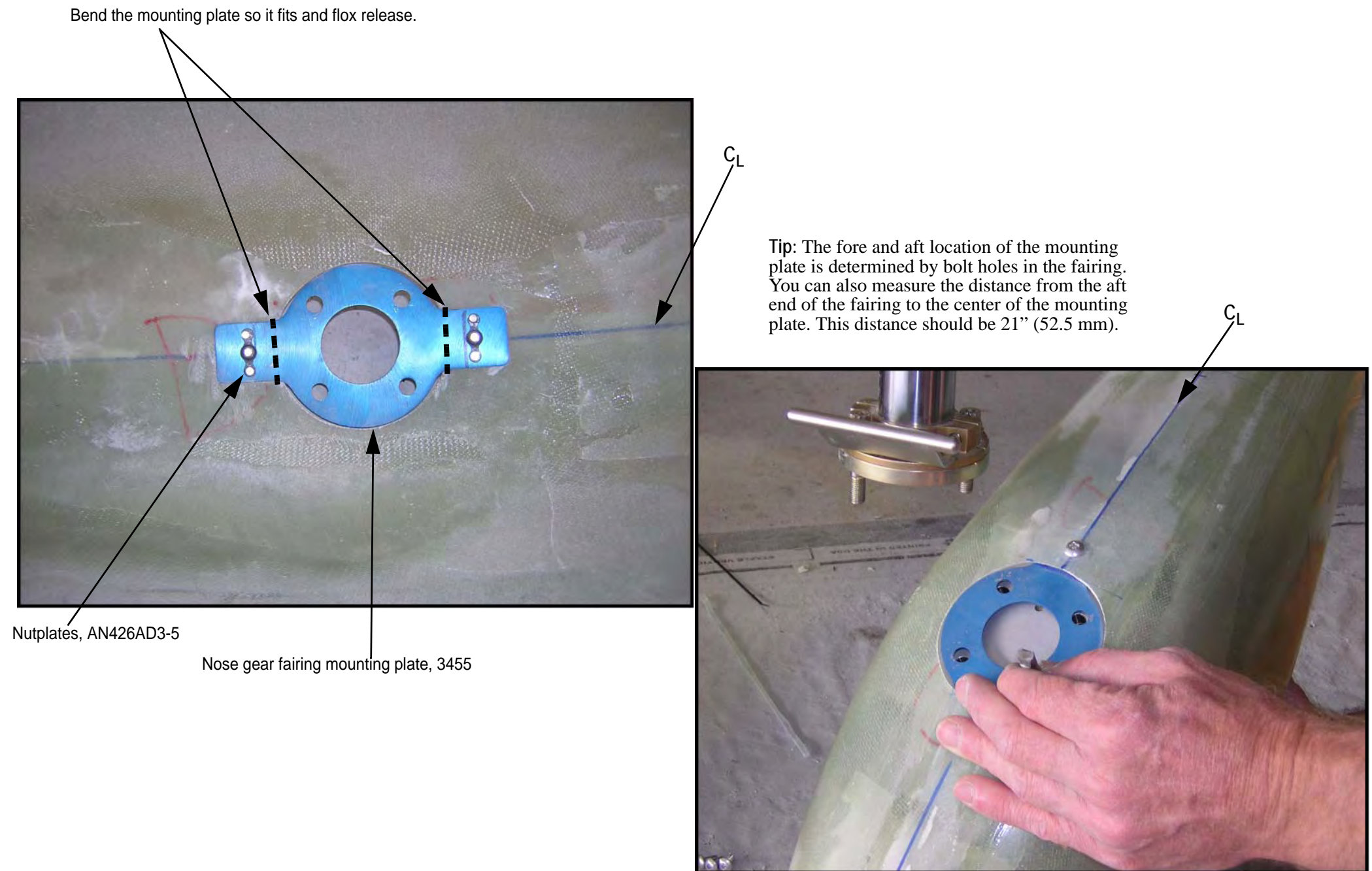

Finishing the Nose Gear Fork Connections

Figure S.6.E.2 Connecting the fairing to the nose gear fork

Note: Newer struts do not use the clamp at the bottom of the strut that is in the two photos at the right.

- The front holes use bolts MS21250-05015.
- The rear holes use bolts MS21250-05013.



Bolts, MS21250-05015 and MS21250-05013
with countersunk washers, MS20002C5.

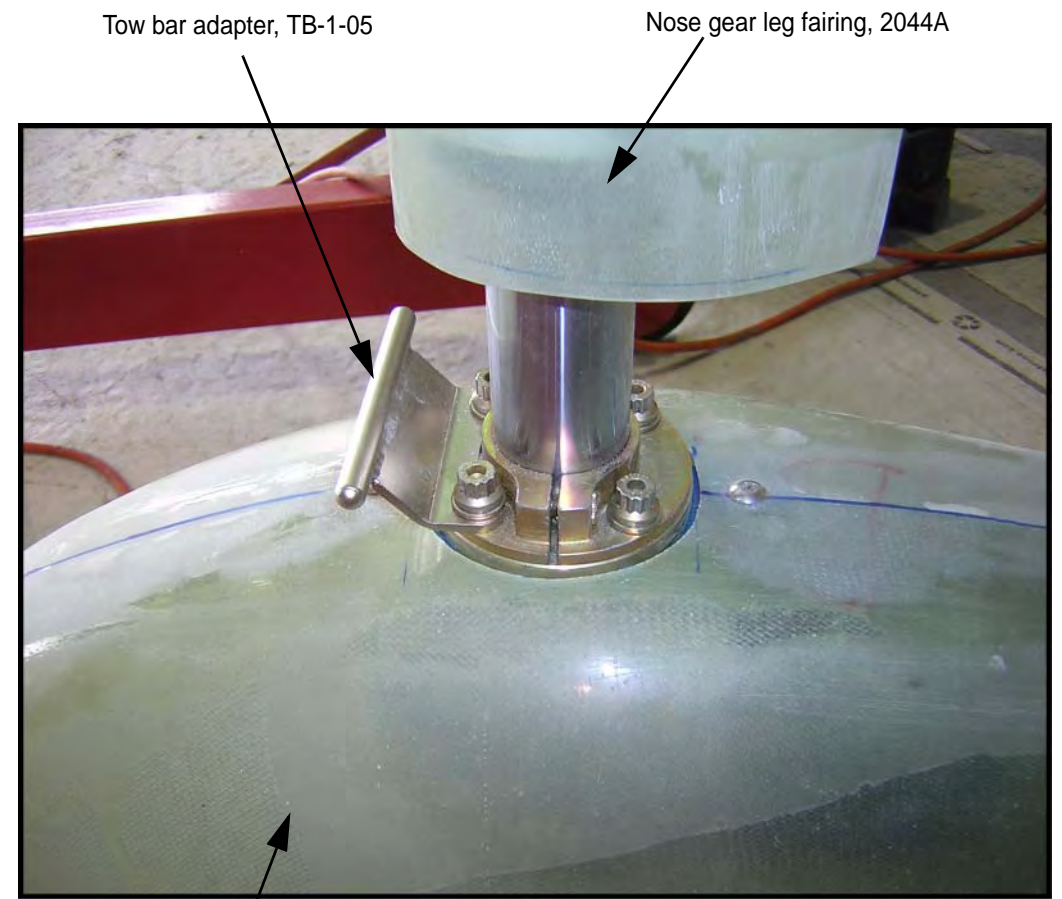

Nose gear wheel pant, 7045

S.6.F Nose Gear Leg Fairing

Figure S.6.F.1 Nose gear leg fairing

Nose gear leg fairing, aft, 2044A

Nose gear leg fairing, forward, 2044F

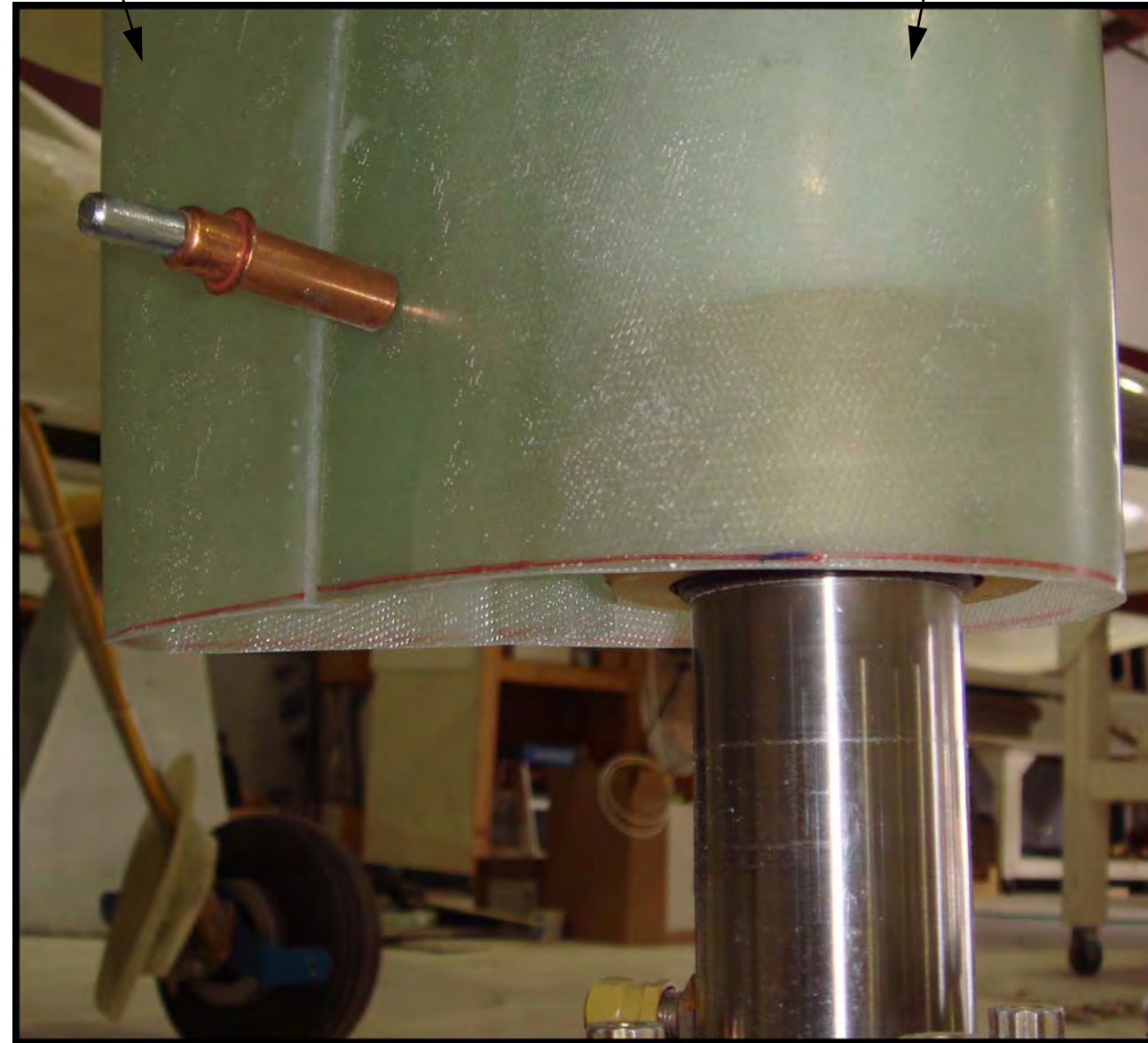
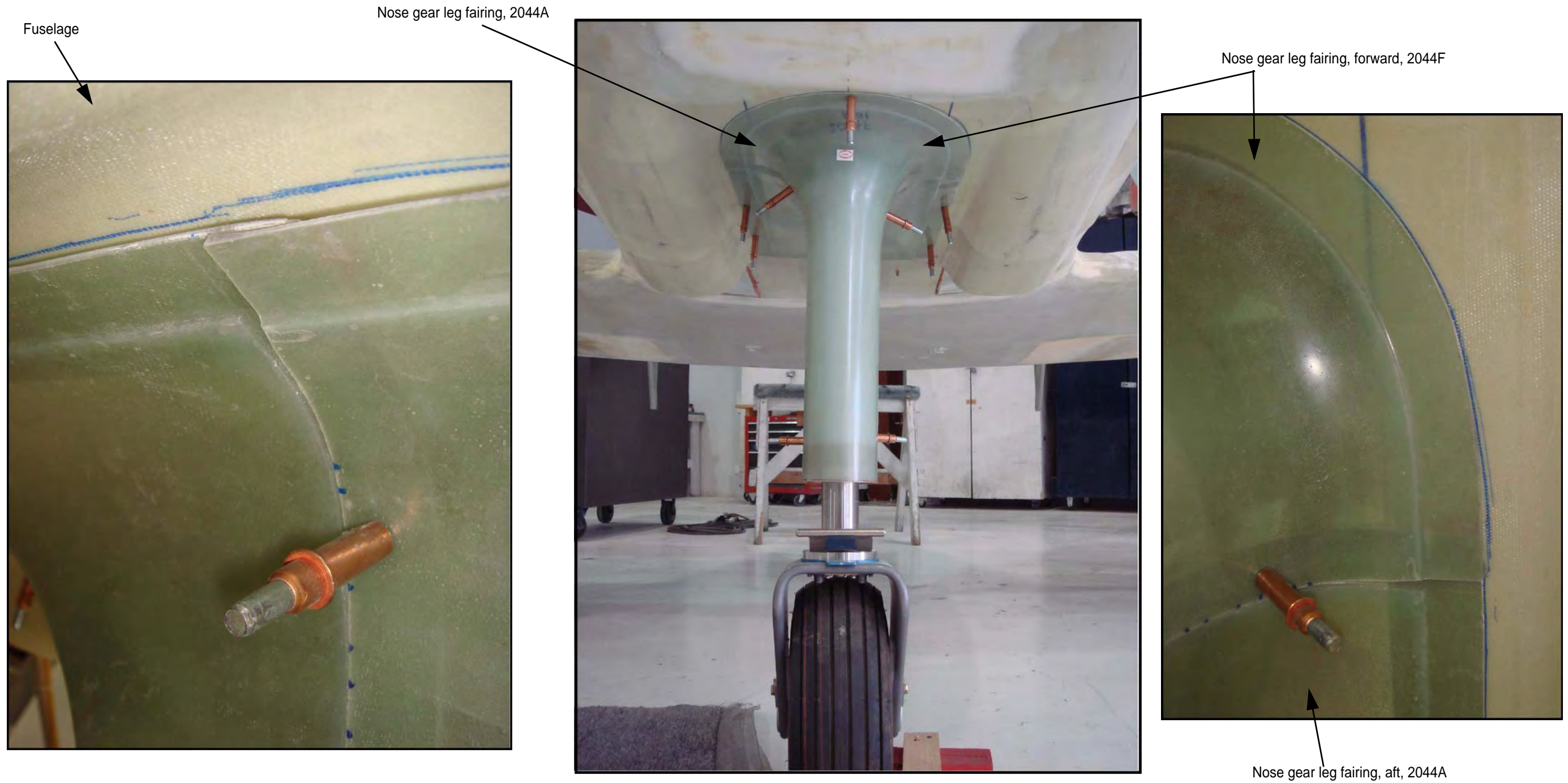

Figure S.6.F.2 Installing the nose gear fairings to the fuselage



S.7 Installing the Idler Assembly

The idler assembly in the Legacy FG is located differently than in the retractable Legacy.

S.7.A Aligning the Idler's Base Bracket



To correctly locate the aileron assembly, the controls must be set to neutral and tested prior to finishing the installation of the base bracket.

Steps...

1. Assemble the aileron idler.
2. Clamp the aileron idler bracket (209-0001) to the wing spar.
3. There are four dots on the spar to help locate the base bracket. Clamp the bracket over these dots so a dot can be seen through each bolt hole.
4. Install the aileron assembly to the base bracket.
5. Install the control stick assembly per page 6-3 in the *Legacy Assembly Manual* and follow the rigging procedure.

Setting the Controls to Neutral

The basis for rigging the aileron control system is to set the stick, idler arm, bellcrank and the aileron to neutral. Then the control tubes are adjusted accordingly.

Steps...

1. Set all inboard controls to neutral.
2. Connect the inboard push-pull tube to the rod-end bearing.
3. Move the control sticks through their entire range of motion, including the maximum elevator travel.

Connecting the Rod-end Bearing to the Push-pull Tube

Rod ends should always maintain at least five threads engaged onto the end of the push-pull tube. The simplest method for connecting a rod-end bearing is as follows:

- Turn the rod end onto the end of the push-pull tube, counting each turn, until it bottoms out.
- Turn the rod end out by 1/2 the total turn count.
- This should be at least or greater than five turns.
- Always check the witness hole.

Figure S.7.A.1 Idler base bracket and assembly

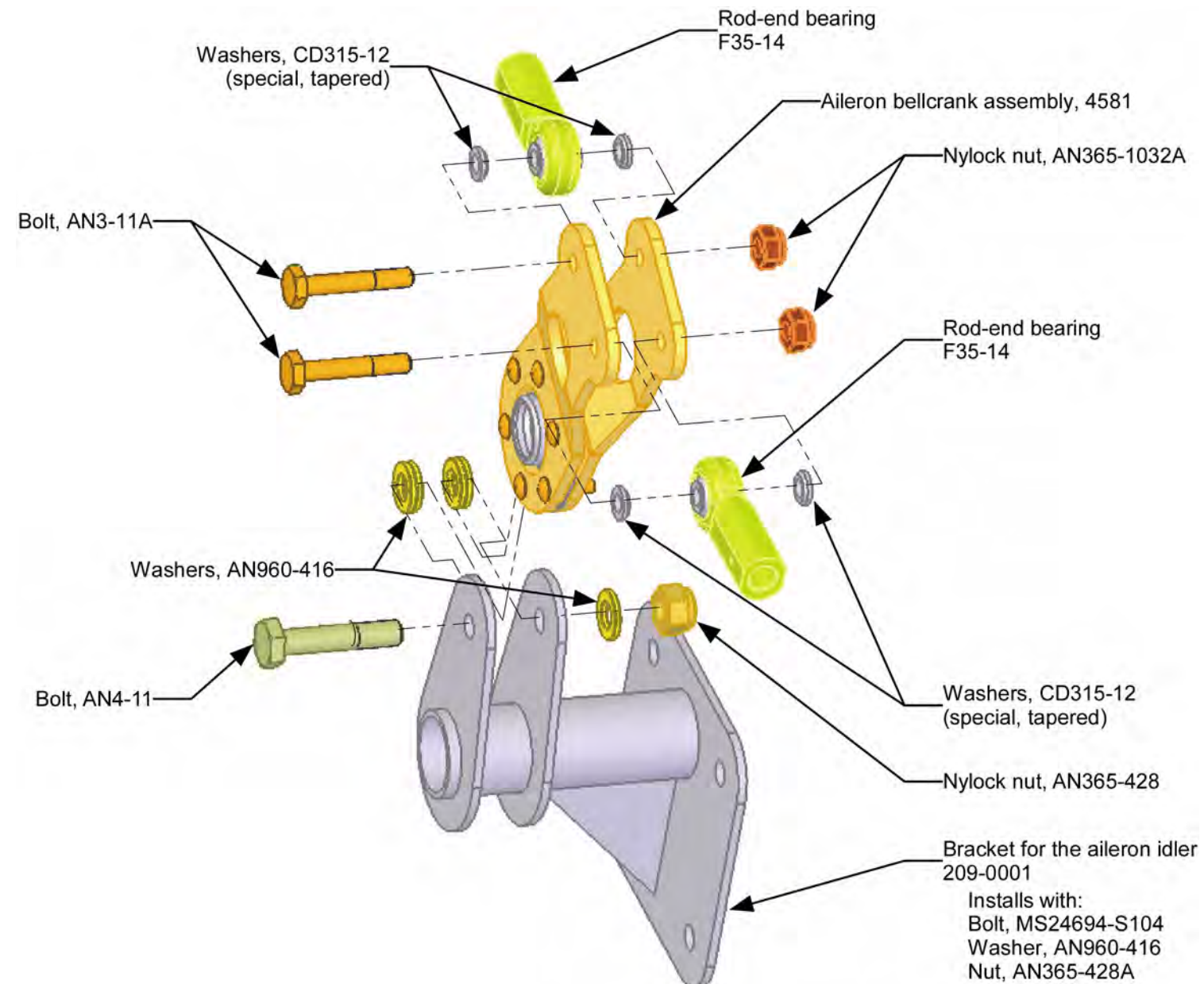

S.7.B Installing the Idler's Base Bracket

When you have determined that the idler's base bracket is in the proper location, finish the installation using these steps.

Adjust the bracket placement for optimal clearance between the push-pull tube and the upper gear weldment while the idler arm is vertical.

Steps...

1. With the base bracket still clamped in place, mark the four locations for the bolt holes.
Your four marks should be thoroughly tested. If you are not positive, repeat the instructions in *Setting the Controls to Neutral* on the previous page.
2. Drill through the spar at each of the bolt hole locations.
3. Bolt the idler's base bracket in place using the following parts:
Bolt, MS24694-S104
Washer, AN960-416
Nut, AN365-428A

Figure S.7.B.1 Assembled idler arm

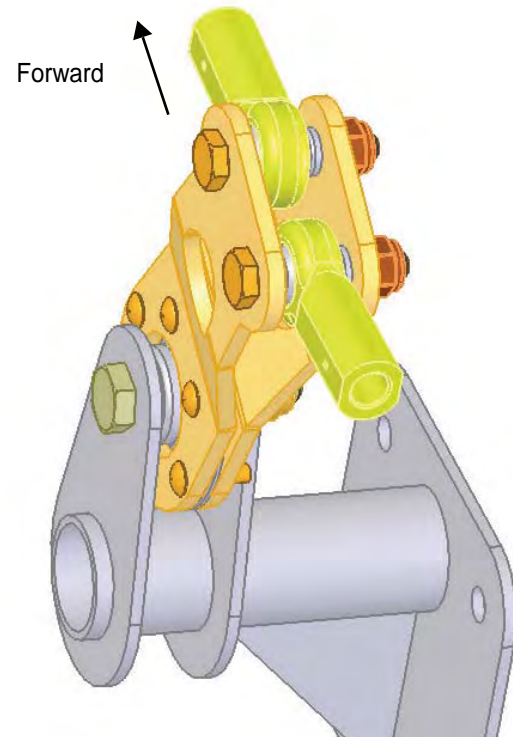
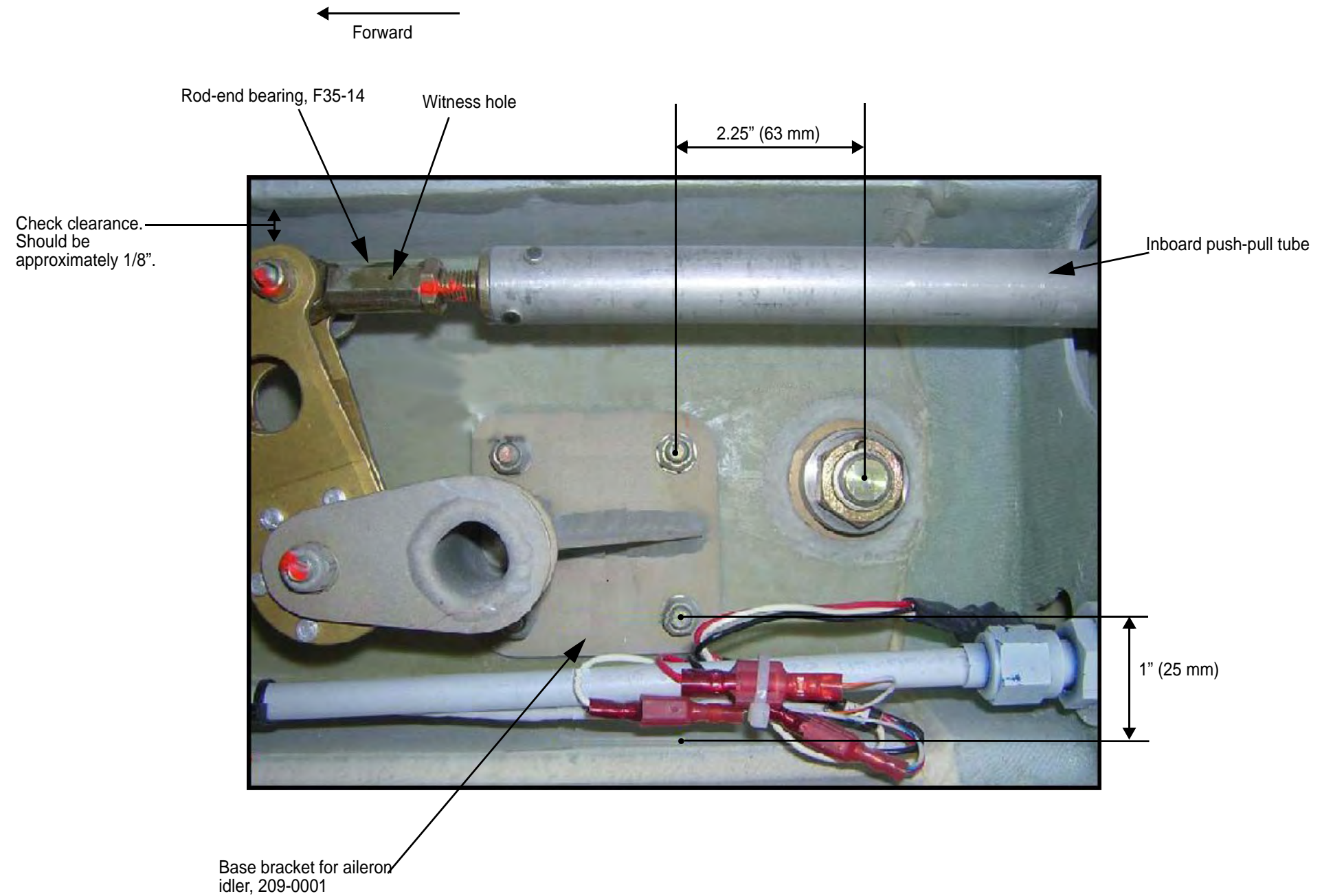
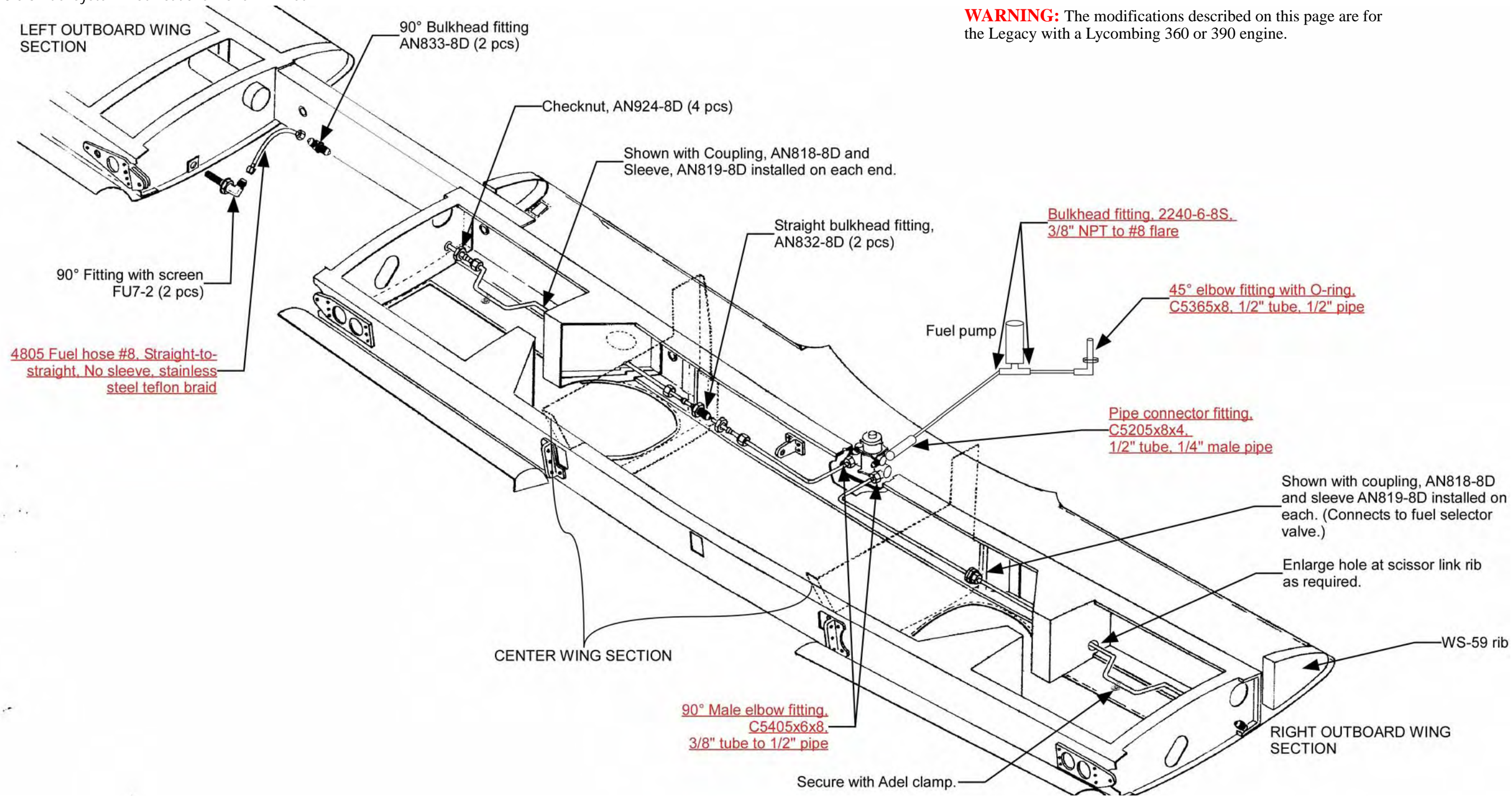

Figure S.7.B.2 Location of the idler's base bracket



S.8 Modifications to the Fuel System

Figure S.8.0.3 Fuel system modifications – shown in red



S.9 Appendix A

S.9.A Alternate Air Assembly for the TNIO 360/390

This appendix applies to both the Legacy RG and the FG when they are powered by the TNIO 360/390.

Figure S.9.A.1 Assembly layout for the TNIO 360/390 alternate air

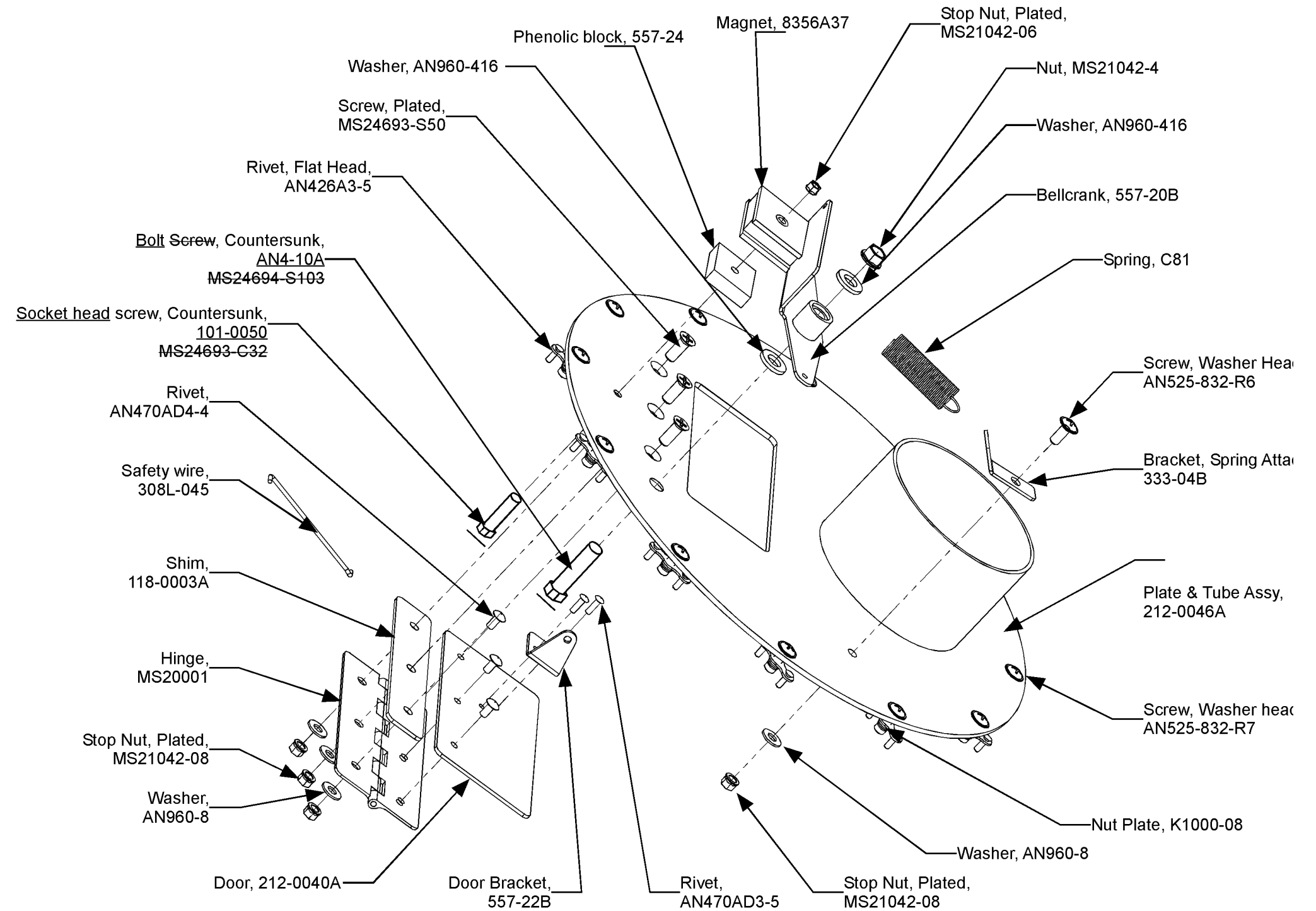

Figure S.9.A.2 Assembly diagram of the alternate air

